

# INSTRUCTION MANUAL POWER UNITS HOME LIFT MH2V DISTRIBUTOR

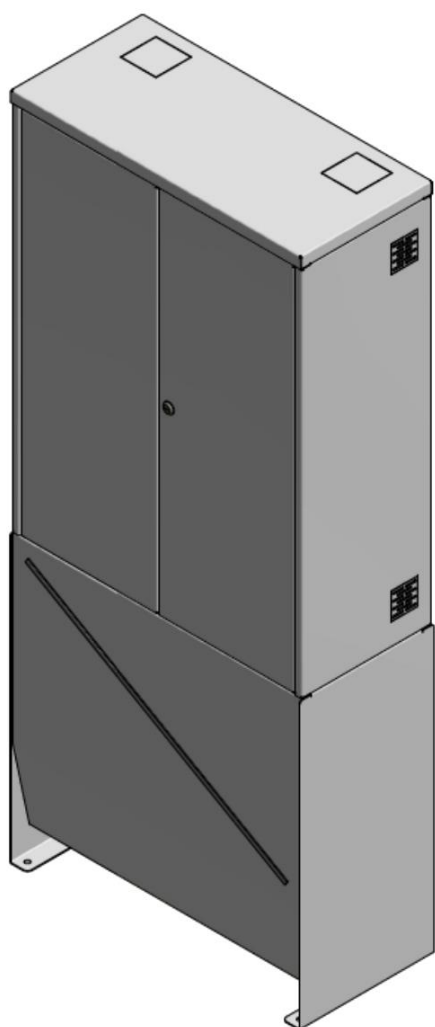



## CONTENTS

<b>1. SUMMARY OF MODIFICATIONS.</b>	<b>2</b>
<b>2. INTRODUCTION.</b>	<b>2</b>
2.1 SCOPE	2
2.2 SYMBOLS USED.	2
2.3 SAFETY DURING THE INSTALLATION.	3
<b>3. GENERAL FEATURES.</b>	<b>3</b>
3.1 DESCRIPTION OF DISTRIBUTORS	3
3.2 TYPE OF HYDRAULIC OIL.	3
3.3 HYDRAULIC FEATURES	4
3.4 ELECTRICAL FEATURES.	4
<b>4. ADJUSTMENTS.</b>	<b>4</b>
4.1 ADJUSTMENT OF MH2V.	5
4.2 RUPTURE VALVE TEST FOR DISTRIBUTORS KV.	7
4.3 ADJUST THE PRESSURE SWITCH.	7
4.4 L10 UCM SYSTEM (OPTIONAL).	8
4.5 HAND PUMP.	8
<b>5. SPARE PARTS.</b>	<b>9</b>
<b>6. ASSEMBLY INSTRUCTIONS OF CABINET (OPTIONAL).</b>	<b>10</b>

The contents of this document are owned by MORISPAIN. It can not be copied without express permission. Before printing, think if it is necessary.

## 1. SUMMARY OF MODIFICATIONS.

VERSION	DESCRIPTION
0	First edition.
1	Updated MS-A / MS-K

## 2. INTRODUCTION.

### 2.1 SCOPE

This document contains installation instructions, commissioning, operation manual, maintenance and repair. The design of this power unit has been made according to machinery directive 42/2006/CE and it is destined for vertical transport of people and goods.

The power unit must be installed by a competent company, always respecting the specifications in this manual, as well as the legal regulations of local country.

Previously to installation, it is compulsory to have knowledge of lift installing, safety rules of the country and have the ability to read technical drawings and the descriptions of this document.

Previously to the commissioning of the lift, it must be done all finals test indicated in the EN81-20 or EN81-2 standard according to the rules that applied.

The maintenance technician must be qualified and have specific knowledge to the activities mentioned in this Instruction Manual. In addition, maintenance and repair activities must be done respecting the technical specifications given in this document.

Before starting the installation Works, it is compulsory read the whole manual, which contains information about:

- Correct installation.
- Safety of technicians.

### 2.2 SYMBOLS USED.



**WARNING:** It points out that, during the described operation, non-compliance with safety rules may cause damages to the installation or serious physical injuries



### 2.3 SAFETY DURING THE INSTALLATION.



**WARNING:** Please read this manual. It contains very important information and notices regarding user safety and technicians.

## 3. GENERAL FEATURES.

### 3.1 DESCRIPTION OF DISTRIBUTORS

The power units are equipped with homelift family of distributors MH2V, these distributors are designed for homelift to 0.15m/s as marks the Machinery Directive and exceptionally outside the EC market up to 0.3m/s.

### 3.2 TYPE OF HYDRAULIC OIL.



**WARNING:** Power units always use hydraulic oil VESTA HM46 or another hydraulic oil with similar ISO degree.

GENERAL FEATURES OF HYDRAULIC OIL HM46	
ISO Degree	46
Viscosity Index	>150
Density at 15°C (g/cc)	0,875
Freezing point (°C)	< -35
Flash point (°C)	>210
Viscosity (40°C) (cSt)	42-50
Viscosity (100°C) (cSt)	7,9-8,5

### 3.3 HYDRAULIC FEATURES

HYDRAULIC FEATURES	
Operation minimum pressure (bar)	3
Operation maximum pressure (bar)	100
Maximum speed (m/s)	0,15 - *0,30
Coil Voltages (Vdc)	12-196
Coil Voltages 50/60Hz (Vac)	24 – 230
Temperature limits (°C)	5 - 70
Pump flows (l/min))	5 - 55

\*outside of European community.

### 3.4 ELECTRICAL FEATURES.

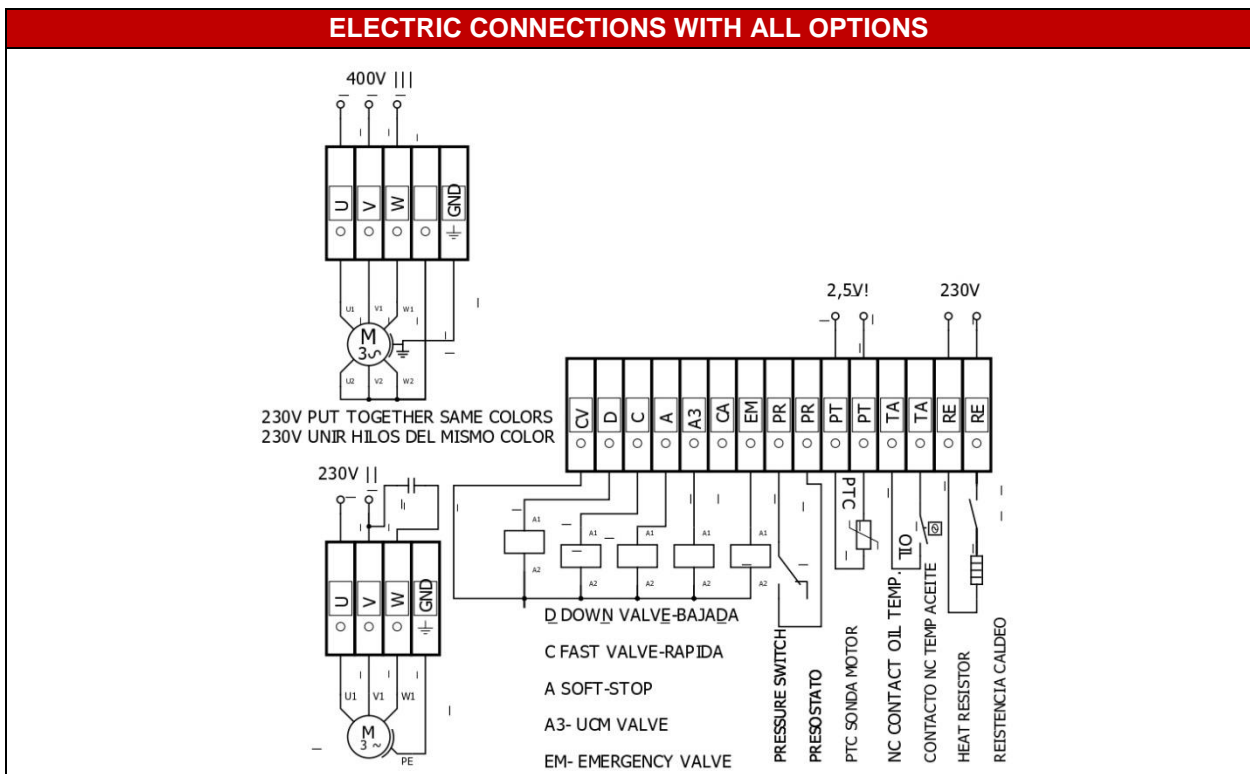

### 4. ADJUSTMENTS.



**WARNING:** All power units produced in MORISPAIN are regulated in our test towers with the parameters of the installation, so it is not necessary to regulate them. During installing process, some problems could appear, please check the electrical connections first before doing any adjustments

**4.1 ADJUSTMENT OF MH2V.**

**KV1S**

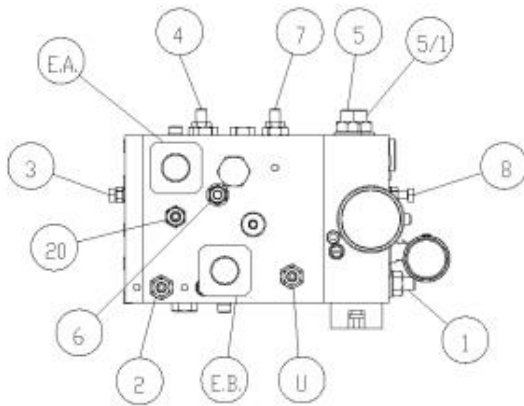

Performance		Screw	Setting	Setting Effect
Rise	By pass pressure	8	↻	Increase
	Acceleration	7 *	↻	Soft
	Max speed	3	↻	Decrease speed
	Deceleration	4 *	↻	Soft
	Low speed	6	↻	Decrease speed
Descent	Acceleration	U *	↻	Soft
	Max speed	20	↻	Increase speed
	Deceleration	4	↻	Soft
	Low speed	6	↻	Decrease speed
Overpressure		5	↻	Increase
Overpressure hand pump		5/1	↻	Increase
Minimum pressure		1	↻	Increase

\* Setting very sensitive MAX 1/6 round at time

For rupture valve test on the jack, rotate ↻ screw n° 2

**ADJUSTMENT**

- SCREW - 1 ADJUSTMENT FOR ROD COUNTERPRESSURE - TIGHTEN SCREW TO INCREASE COUNTERPRESSURE
- SCREW - 2 ADJUSTMENT AND TEST OF SAFETY VALVE FOR ROD FAILURE (SEE DWG N°9345)
- SCREW - 3 ADJUSTMENT FOR HIGH SPEED BALANCING IN UP/DOWN DIRECTION - TIGHTEN SCREW TO REDUCE SPEED
- SCREW - 4 ADJUSTMENT FOR 1ST DECELERATION PHASE - SCREW DOWN FOR A SOFT DECELERATION
- SCREW - 5 ADJUSTMENT FOR MAX. PRESSURE - TIGHTEN SCREW TO INCREASE PRESSURE
- SCREW - 5/1 REG. MAX PRESSURE HAND PUMP - UNSCREWING INCREASES PRESSURE
- SCREW - 6 ADJUSTMENT FOR LOW SPEED IN UPWARD AND DOWNWARD DIRECTION - TIGHTEN SCREW TO REDUCE SPEED
- SCREW - 7 ADJUSTMENT FOR DEPARTURE IN UPWARD DIRECTION - TIGHTEN SCREW FOR SOFT DEPARTURE (1)
- SCREW - 8 ADJUSTMENT FOR VALVE "D" COUNTERPRESSURE - TIGHTEN SCREW TO INCREASE COUNTERPRESSURE
- SCREW - 20 ADJUSTMENT FOR DOWNWARD DIRECTION SPEED - TIGHTEN SCREW TO INCREASE SPEED
- E.A VALVE FOR HIGH SPEED IN UP/DOWNWARD DIRECTION
- E.B DOWNWARD DIRECTION VALVE
- L PUSH BUTTON FOR MANUAL EMERGENCY IN DOWNWARD DIRECTION
- Pm MANUAL PUSH BUTTON FOR STARTING EMERGENCY VALVE
- R TAP TO CUT OFF PRESSURE GAUGE
- SCREW - U DOWNWARD DEPARTURE DEVICE - TIGHTEN SCREW TO REDUCE SPEED (1)

**NOTE (1):** DO NOT TIGHTEN COMPLETELY, SINCE DEPARTURE MOVEMENT MAY BE INTERRUPTED

**OPERATION**

- INSERTING ELECTRIC MOTOR, REG. DELAY HYDRAULIC THROUGH SCREW 7/a
- MOTOR SUPPLY AND E.A. VALVE EXCITATION
- ACCELERATION IN UPWARD DIRECTION - ADJUST USING SCREW 7
- CONSTANT HIGH SPEED IN UPWARD DIRECTION - ADJUST USING SCREW 3
- 1ST DECELERATION PHASE FROM HIGH TO LOW SPEED - E.A. DE-ENERGIZED ADJUST USING SCREW 4
- CONSTANT LOW SPEED IN UPWARD DIRECTION - ADJUST USING SCREW 6
- 2ND DECELERATION PHASE TO FLOOR LEVEL (MOTOR OFF)
- E.A./E.B. VALVES EXCITATION - ACCELERATION IN DOWNWARD DIRECTION ADJUST USING SCREW U
- CONSTANT HIGH SPEED IN DOWNWARD DIRECTION - ADJUST USING SCREW 20
- 1ST DECELERATION PHASE - E.A. VALVE DE-ENERGIZED ADJUST USING SCREW 4
- CONSTANT LOW SPEED IN DOWNWARD DIRECTION - ADJUST USING SCREW 6
- 2ND DECELERATION PHASE TO FLOOR LEVEL - E.B. VALVE DE-ENERGIZED

**NOTE:** DURING THE DE-ENERGIZING PHASE OF E.A. VALVE, MAKE SURE THAT AFTER THE PHASE OF DECELERATION, THE DISTANCE AT WHICH LOW SPEED BEGINS IS AT LEAST 15/20 cm BEFORE LEVEL STOP

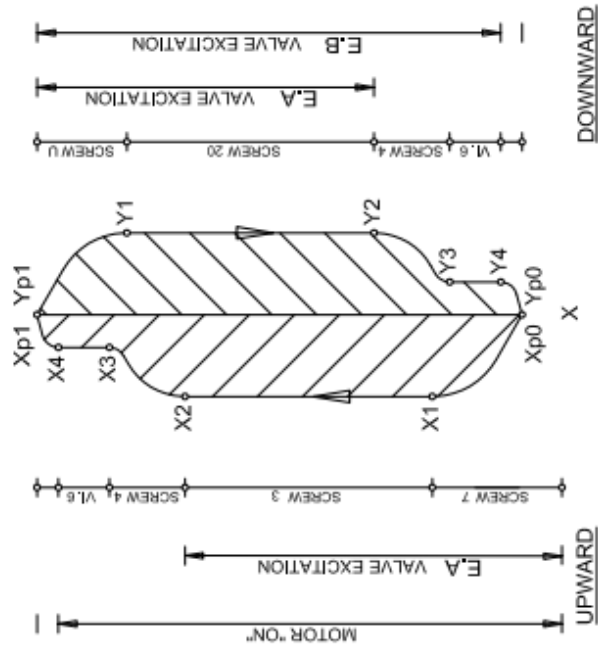
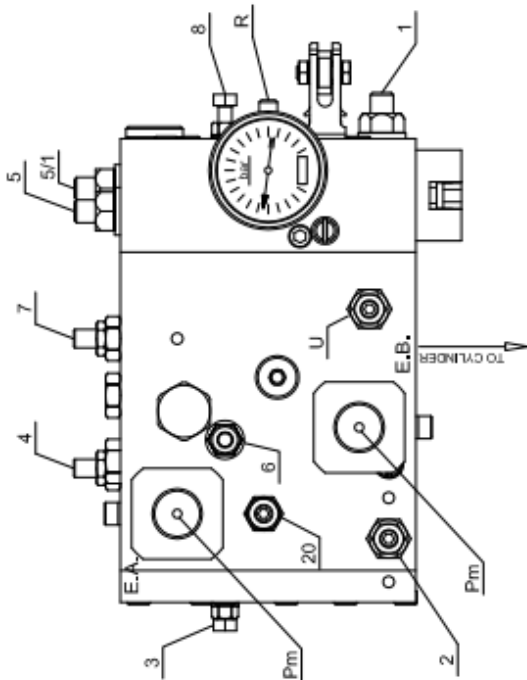



#### 4.2 RUPTURE VALVE TEST FOR DISTRIBUTORS KV.

Do the next procedure to test the rupture valve:

1. Prepare the car fully charged and send the car to highest floor level.
2. Increase the downward speed. Close screw nº 2 (clockwise).
3. Set downward travel and check the rupture valve functions (manometer goes to 0 bar).
4. If the rupture valve works properly, set the screw 2 on the original position.
5. Check one more time fully charged that rupture valve doesn't cut the oil flow in downward travel.



**WARNING:** All rupture valves supplied for Morispain have been calibrated in the test tower.

In case of you need to adjust it, tight ¼ turn (clockwise) the adjustment screw of the rupture valve and repeat the test until it functions.

If you are using other rupture valve, read the instruction manual of that valve to adjust it.

#### 4.3 ADJUST THE PRESSURE SWITCH.

All power units have a pressure switch which can be adjusted. The pressure switch has normal opened and normal closed connection.

The preset pressure is adjusted working on the central screw with a 2mm hexagonal key. Rotating clockwise the set point is increased and vice-versa is decreased.

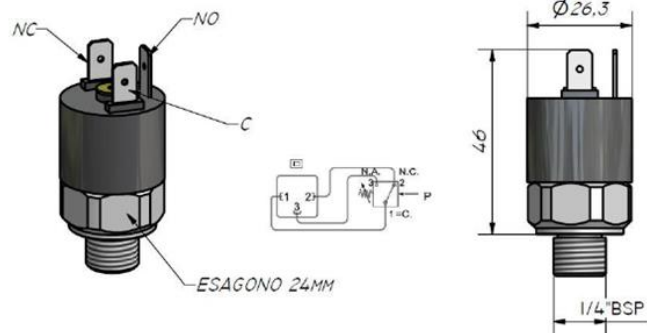

#### 4.4 L10 UCM SYSTEM (OPTIONAL).



As an option you can install a L10 Pressure Lock Valve to prevent UCM, in certain countries outside the European community may be a mandatory requirement.

If you have installed the L10 block is necessary to supply the solenoid in case of rescue for its descent.

If manual emergency descent is only necessary act key block L10.

#### 4.5 HAND PUMP.

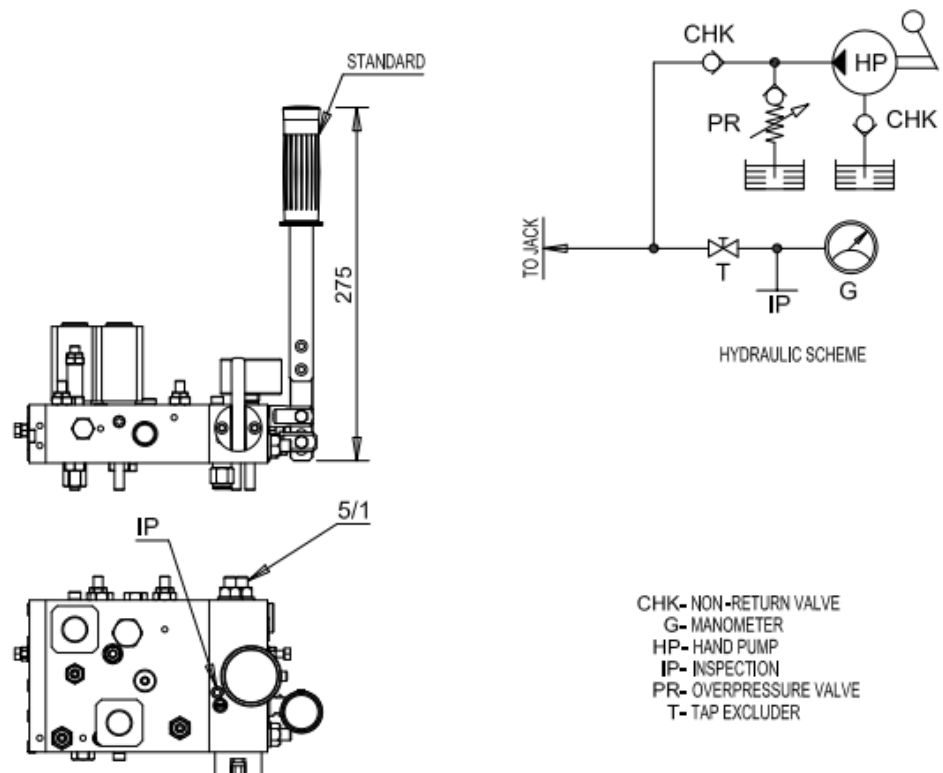

#### NOTES FOR HAND PUMP SETTING (ADJUSTMENT)

- BEFORE APPLYING VOLTAGE TO THE MOTOR, ACTIVATE THE HAND PUMP AS FOLLOWS:

- ① - UNSCREW THE SCREW IP FOR ABOUT 3 TURNS.
- ② - OPERATE THE HAND PUMP UNTIL OIL COMES FROM THE SCREW IP.
- ③ - IF NO OIL COMES OUT, UNSCREW THE SCREW IP AND FILL THE HOLE WITH OIL TO THE EDGE AND THEN REPEAT STEP ②
- ④ - TIGHTEN THE SCREW IP UNTIL IT STOPS.

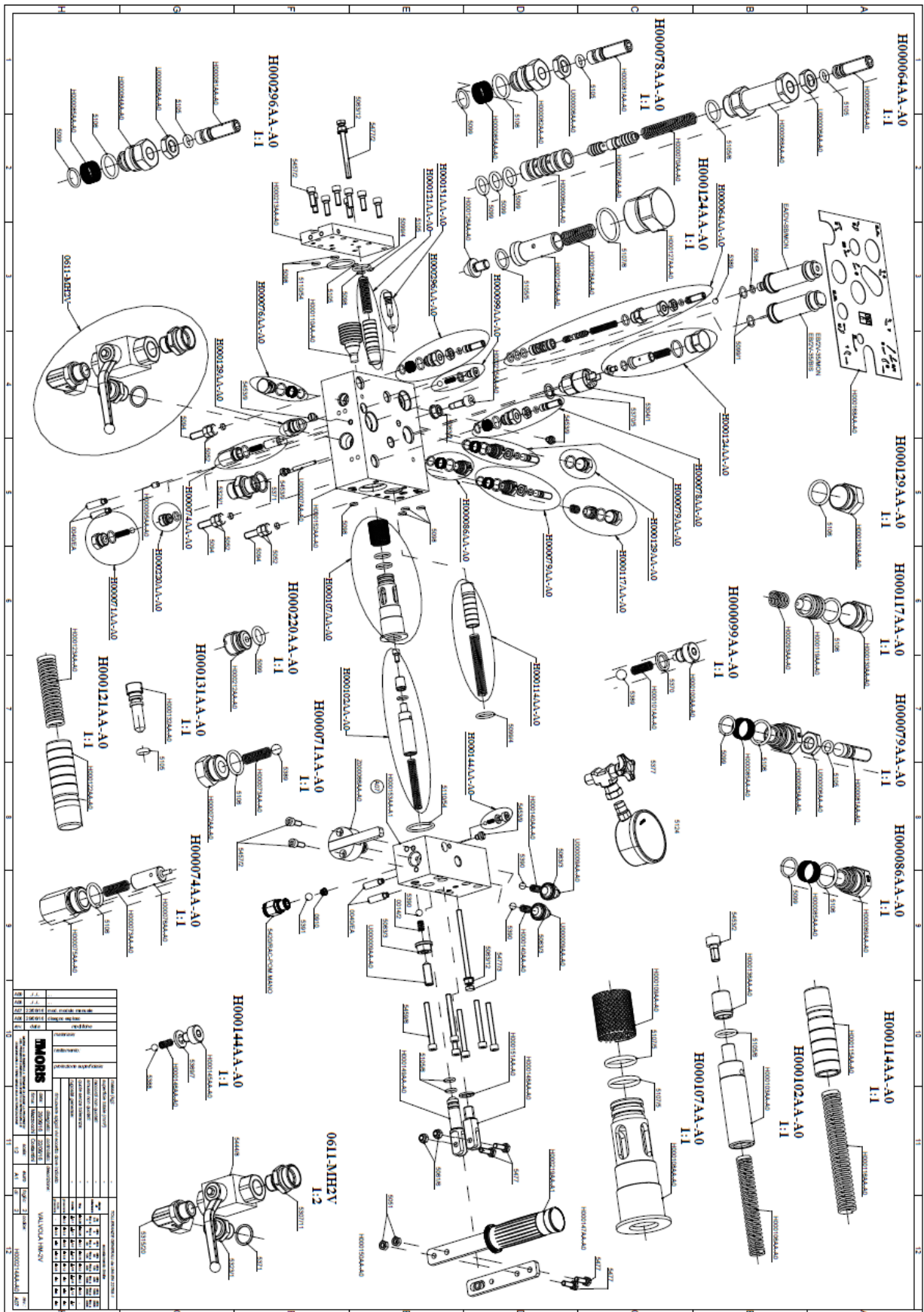

- FOR DIFFERENT PRESSURES ADJUST SCREW N° 5/1.  
(TURNING CLOCKWISE THE PRESSURE INCREASES)

**5. SPARE PARTS.**



PARTS LIST			
NO.	DESCRIPTION	UNIT	QTY.
01	0611-AH2V		1
02	H000064AA-A0		1
03	H000078AA-A0		1
04	H000129AA-A0		1
05	H000177AA-A0		1
06	H000099AA-A0		1
07	H000086AA-A0		1
08	H000114AA-A0		1
09	H000102AA-A0		1
10	H000107AA-A0		1
11	H000296AA-A0		1
12	H000311AA-A0		1
13	H000214AA-A0		1
14	H000220AA-A0		1
15	H000131AA-A0		1
16	H000071AA-A0		1
17	H000074AA-A0		1
18	H000144AA-A0		1

**6. ASSEMBLY INSTRUCTIONS OF CABINET (OPTIONAL).**

	<b>4x</b>		<b>4x</b>
	<b>24x</b> (DIN.912.M6x16)		<b>4x</b> (DIN.125-M10)
	<b>16x</b> (DIN.934-M6)		<b>4x</b> (DIN.934-M10)
	<b>4x</b> (DIN.7991-M4x20)		<b>1x</b>
	<b>4x</b> (DIN.1587-M4)		<b>1x</b>
	<b>2x</b>		<b>4x</b>

