

Installation • Assembly

Car Lift TAURUS

SUMMARY OF CHANGES COMPARED TO THE PREVIOUS VERSION:

MTMEC_MTC_103_EN

PUNTO DEL ÍNDICE	DESCRIPCIÓN DEL CAMBIO	EL CAMBIO AFECTA A			
		Producto Físico	Funciones Prestaciones	Figuras	Redacción del manual
3.3	Assembly of the cross plates of the longitudinal beams.	<input checked="" type="checkbox"/>	<input type="checkbox"/>	<input type="checkbox"/>	<input type="checkbox"/>
3.10	Installation of the front car frame profile.	<input checked="" type="checkbox"/>	<input type="checkbox"/>	<input type="checkbox"/>	<input type="checkbox"/>
		<input type="checkbox"/>	<input type="checkbox"/>	<input type="checkbox"/>	<input type="checkbox"/>
		<input type="checkbox"/>	<input type="checkbox"/>	<input type="checkbox"/>	<input type="checkbox"/>
		<input type="checkbox"/>	<input type="checkbox"/>	<input type="checkbox"/>	<input type="checkbox"/>
		<input type="checkbox"/>	<input type="checkbox"/>	<input type="checkbox"/>	<input type="checkbox"/>
		<input type="checkbox"/>	<input type="checkbox"/>	<input type="checkbox"/>	<input type="checkbox"/>

ÍNDICE

0. MAIN ACRONYMS, ABBREVIATIONS AND RECOMMENDATIONS.....	5
1. SAFETY	6
1.1. Reference Standars.....	6
1.2. Symbols used.....	6
1.3. Safety during installation	6
1.4. Documentation for installation	7
2. GUIDE RAILS BED PLATE	7
2.1. Installation of guide rails bed plate and car guide rails	7
2.2. Installation of ropes bed beam	8
2.3. Installation of guide rails brackets	8
2.4. Jack Beam installation.	8
2.5. Jack guide Rails Installation.	9
2.6. Jack Installation.	10
2.7. Pulley Installation.	10
3. CAR FRAME.....	12
3.1. Vertical Beams Installation.....	12
3.2. Installation of limit switch, and magnets detectors.....	13
3.3. Assembly of the cross plates of the longitudinal beams.....	13
3.4. Installation of the traction Beam.....	15
3.5. Installtion of the secondary car frame beams.	15
3.6. Installation of the internal crossing secondary beams.....	16
3.7. Installation of the external crossing secondary beams.....	16
3.8. Installation of the internal car frame bed profiles.....	17
3.9. Installation of the external car frame profiles.	17
3.10. Installation of the front car frame profile.....	17
3.11. Installation of safety gear car frame fixation plates	18
3.12. Installation of steel floor rail.....	19
3.13. Installation of ribbed steel floor right rails.....	19
3.14. Installation of ribbed steel floor left rails.	20
4. INSTALLATION OF SAFETY GEAR TRANSMISION BAR.	21
4.1. Installation of Safety Gear Transmision bar.....	21
4.2. Installation of safety gear lever	22
5. INSTALLATION OF SKIRTING BOARD AND LINTEL	22
5.1. Installation of the 2 Skirting.....	22
5.2. Assembly of the front shelf support brackets on the skirting board.....	24
5.3. Installtion of lintels	24
5.4. Mounting of the front shelf support brackets on the lintel.....	25
6. ASSEMBLY OF THE FRONT PLATES.....	26
6.1. Mounting of the outer front shelves.....	26
6.2. Assembly of the inner front panels.....	26
6.3. Assembly of the button PANEL.	27
7. ASSEMBLY OF THE BUTTON POST.....	29
7.1. Assembly of the button plate.....	29
7.2. Fixing of the pushbutton tube to the Car Frame.....	29
7.3. Assembly of the blind post cap.	31
Once the push button tube has been positioned, it is necessary to cover the other 3 possible positions and its 4 symmetrical positions located under the push button tray.	31
8. ASSEMBLY OF THE PHOTOCELLS.....	31
8.1. Positioning of the photocell tubes and line of coverage.	31
8.2. Positioning of the outer light curtains on the tube.	32
8.3. Positioning of the inner light curtains in the tube.	32
8.4. Attachment of the light curtain tubes to the chassis.	33
8.5. Safety plate installation.	34

8.6. Fixation of the Curtain on the Safety plate	35
9. ASSEMBLY OF THE SKIRTS.	35
9.1. Assembly of the skirts.	35
10. MOUNTING THE LIMIT SWITCH AND THE DOOR PRESENCE CONTACT.	36
10.1. Assembly of the limit switch lever.	36
10.2. Installation of the door zone Contact.	37
10.3. Installation of the door zone levers.	37
11. SCREWDRIVERS	39
11.1. BAG ⁰ 1 : Screws of mean bedplate to the frame	39
11.2. BAG N ^o 2 : Screws of mean bedplate to the ropes beam.....	39
11.3. BAG N ^o 3: Screws of the mean bedplate to the cantilever beams.....	40
11.4. BAG N ^o 4: Screws os auxiliary beams.....	40
11.5. BAG N ^o 6 : Screws of the bed profiles	41
11.6. BAG N ^o 6 : Screws of cabin floor	41

0. MAIN ACRONYMS, ABBREVIATIONS AND RECOMMENDATIONS

Main acronyms, abbreviations and recommendations	Description
Recommended tightening torque for an M6 bolt	10 Nm
Recommended tightening torque for an M8 bolt	25 Nm
Recommended tightening torque for an M10 bolt	50 Nm
Recommended tightening torque for an M12 bolt	87 Nm
Recommended tightening torque for an M20 bolt	411 Nm



¡IMPORTANT! Before starting the assembly of the car lift, please analyse the layout drawings supplied with the order.:

- DRAWING C01-CH-6100.
- DRAWING C01-CH-6010.
- DRAWING C01-CH-3000.

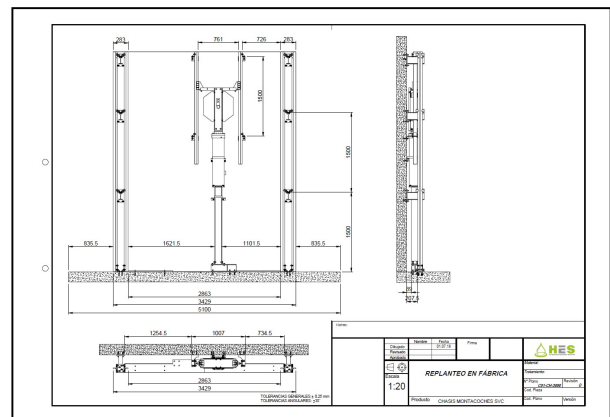
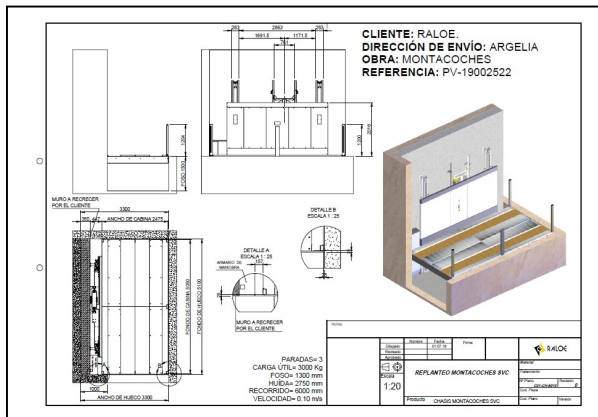

1. SAFETY

1.1. Reference Standards

In this manual, the definitions given in the standards apply:

- DIRECTIVE 2006/42/EC: Machinery Directive.
- EN 81-2: Safety rules for the construction and installation of lifts.
- EN 81-20: Safety rules for the construction and installation of lifts. Safety rules for the construction and installation of lifts - Lifts for the transport of persons and goods - Part 20: Lifts for the transport of persons and loads Part 20: Lifts for persons and persons and goods - Safety rules for the construction and installation of lifts
- EN 81-50: Safety rules for the construction and installation of lifts.
- EN 81-50: Safety rules for the construction and installation of lifts - Part 50: Safety rules for the construction and installation of lifts. EN 81-50: Safety rules for the construction and installation of lifts. Part 50: Rules for the design, calculation, inspection and testing of lift components.
- EN 12100:2010: Safety of machinery - General principles for design. EN 12100:2010: Safety of machinery - General principles for design - Risk assessment and risk reduction.
- ISO 3864: Graphical symbols - Safety colours and safety signs.

1.2. Symbols used



NOTE:

Draws the attention of Commissioning and Maintenance personnel to information whose content is of relevant importance.



ATTENTION : Notes that, in the described operation, failure to follow and respect safety rules may result in damage to the installation or serious physical damage.

1.3. Safety during installation

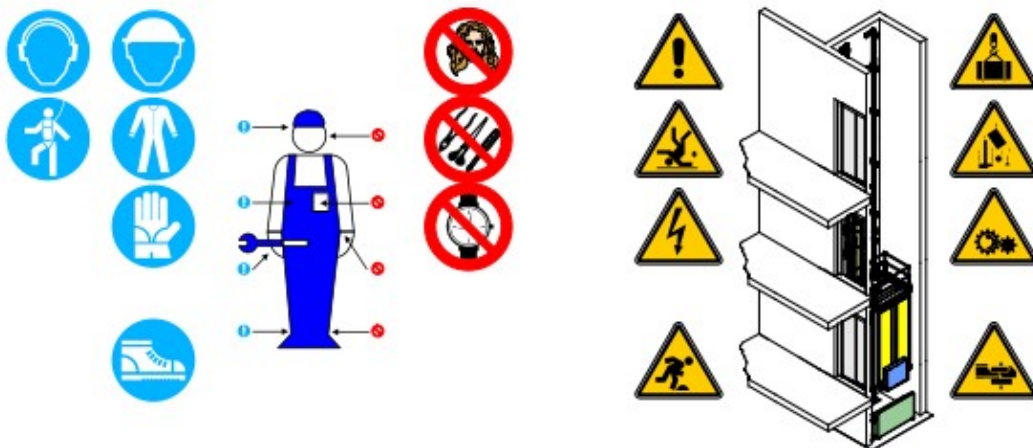

ATTENTION: Before starting any installation operation, ALWAYS check that all safety devices, mechanical and/or electrical, are activated and working properly..

1.4. Documentation for installation

All documentation for the correct and safe maintenance of the car lift must be kept by the person responsible for the installation and maintenance. It should be remembered that this documentation is considered an integral part of the installation.

2. GUIDE RAILS BED PLATE

2.1. Installation of guide rails bed plate and car guide rails

- Check the plan and elevation of the opening where the car lift is to be installed from the corresponding order.
- It is very important to perfectly square the hole, see REPLANNING and follow the dimensions indicated in the corresponding plan.
- Before proceeding to cut the car guides (if necessary) that are used for the first section of guides in the pit, see the elevation with the order supplied from the PLANS of this assembly manual, where the assembly method is indicated in detail.

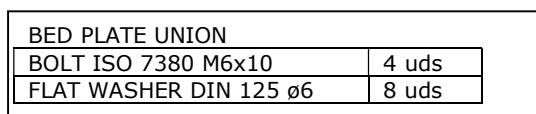
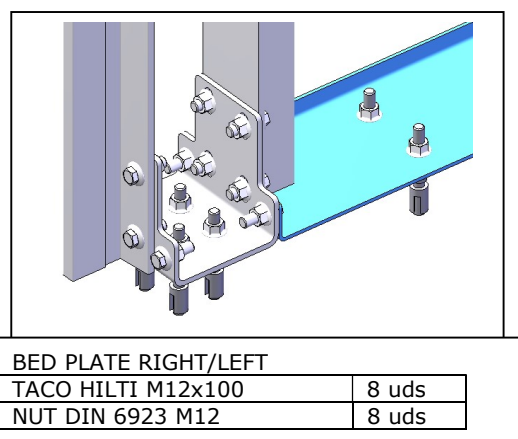
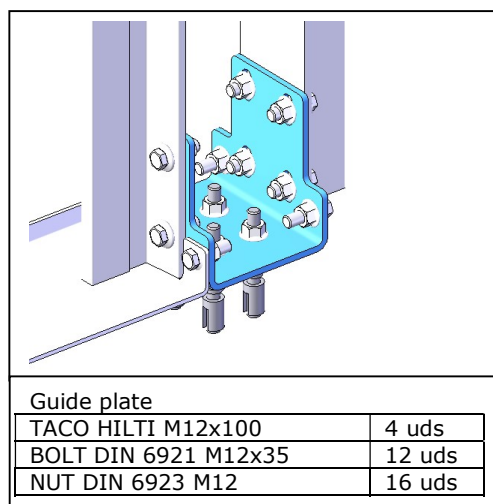
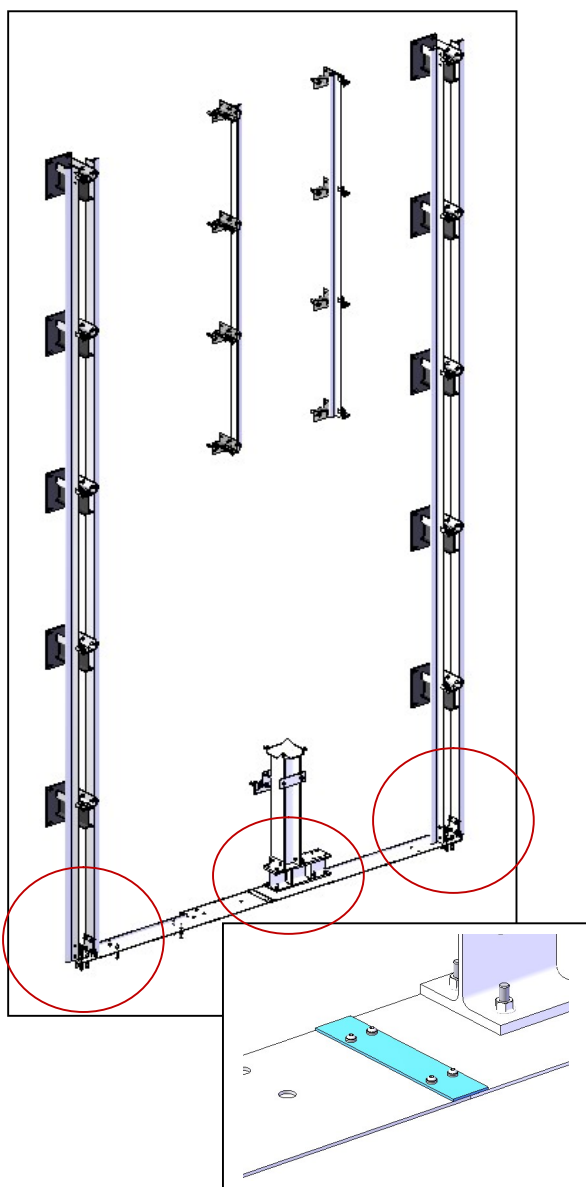

2.2. Installation of ropes bed beam

The base profile will allow us to fix the beam as well as to fix the cable terminals.

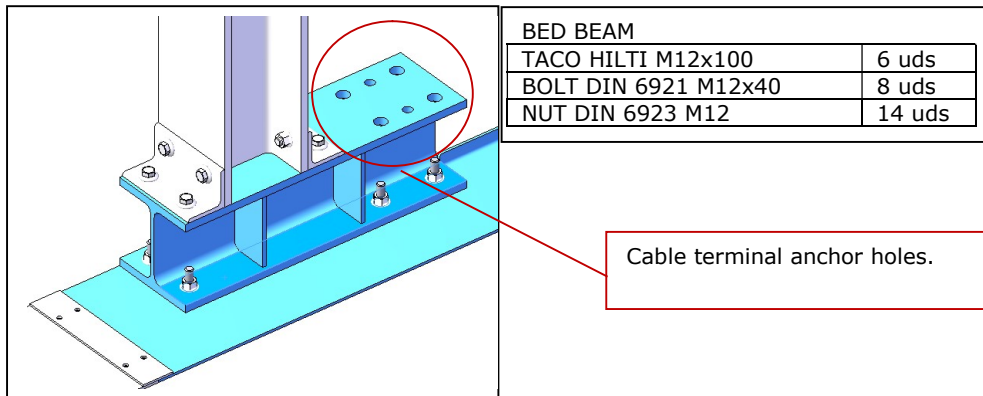

2.3. Installation of guide rails brackets

- * Forged clips and bolts are supplied into wooden box
- * Bracketes Will be installed with 1500 mm between them.

GUIDE RAILS BRACKETS		
TACO HILTI M12x100		4 uds
BOLT DIN 6921 M12x35		4 uds
NUT DIN 6923 M12		8 uds
FORGED CLIP M14		4 uds

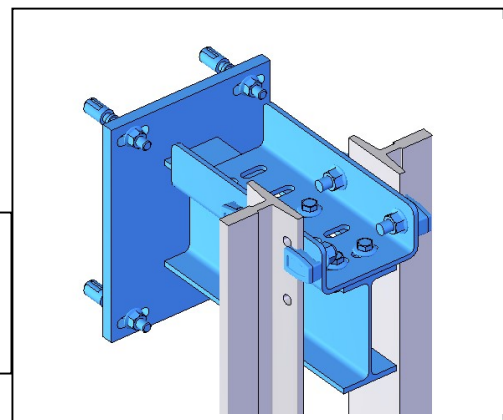

2.4. Jack Beam installation.

As can be seen in the previous image, the cylinder is aligned with the beam by means of the centring bolts on the lower part of the beam. When the base of the cylinder rests on the ashtay of the beam, it will be fixed by means of the screws indicated. Finally, the assembly is as shown in the previous image.

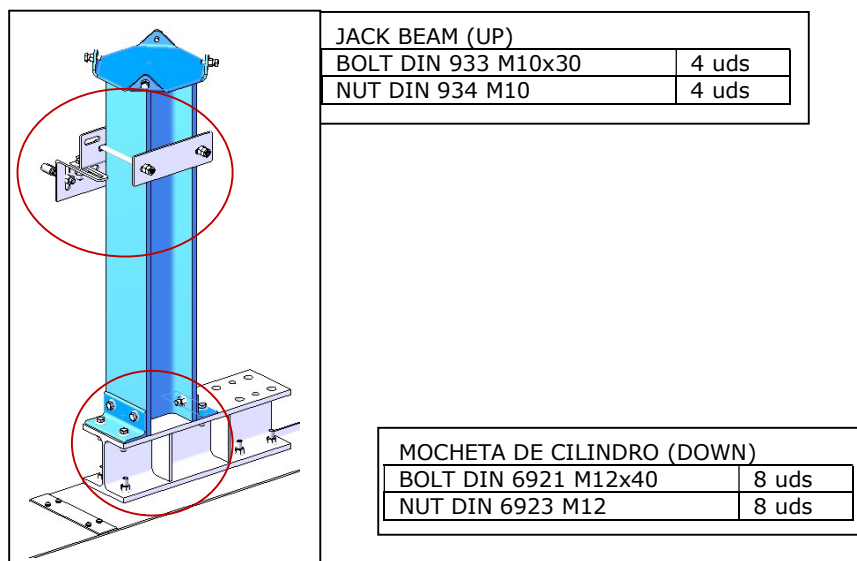

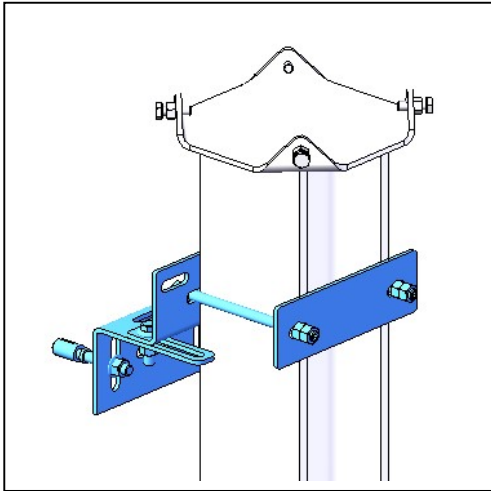

JACK BEAM BRACKET	
TACO HILTI M12x100	2 uds
NUT DIN 6923 M12	4 uds
FLAT WASHER DIN 125 ø12	2 uds
BOLT DIN 975 M12x200	2 uds
NUT DIN 934 M12	8 uds
BOLT DIN 6921 M12x35	2 uds

NOTE: The mounting bracket shall be positioned at the height indicated on the elevation plan..

2.5. Jack guide Rails Installation.

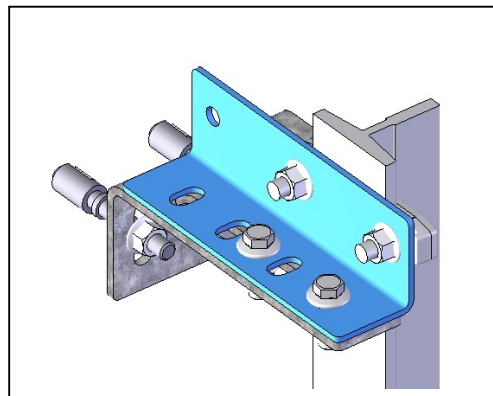
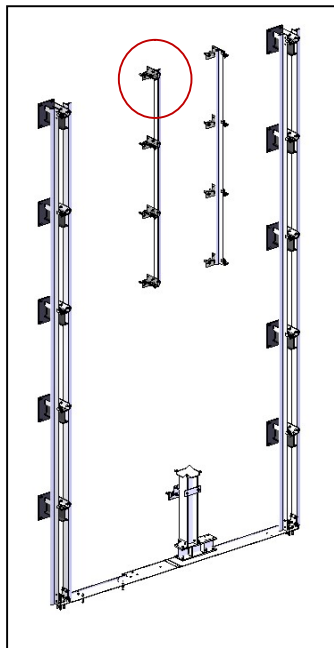

JACK BRACKETS	
TACO HILTI M12x100	2 uds
BOLT DIN 6921 M12x35	2 uds
NUT DIN 6923 M12	4 uds
FORGED CLIP M14	2 uds

* Forged clips are supplied into wooden box.

2.6. Jack Installation.

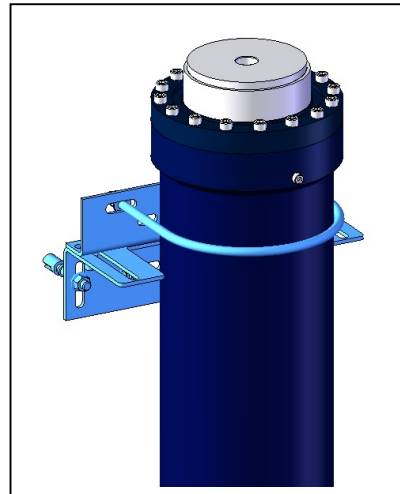
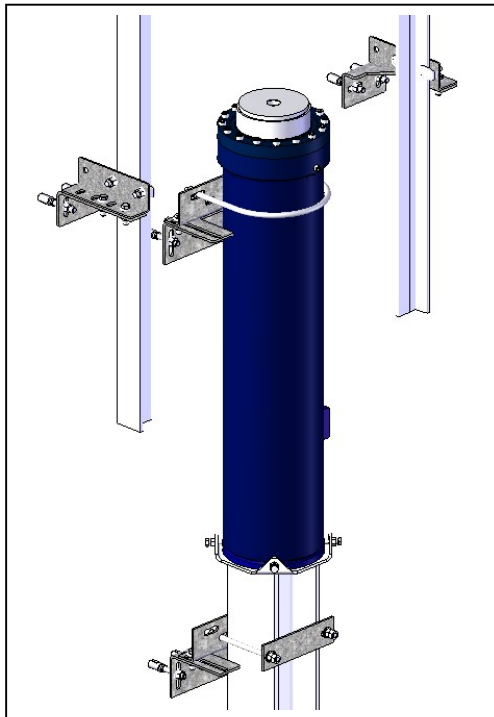

JACK BRACKET	
TACO HILTI M12x100	2 uds
NUT DIN 6923 M12	4 uds
BOLT BRACKET	1 ud
NUT DIN 934 M12	4 uds
FLAT WASHER DIN 125 ø12	2 uds
BOLT DIN 6921 M12x35	2 uds

2.7. Pulley Installation.

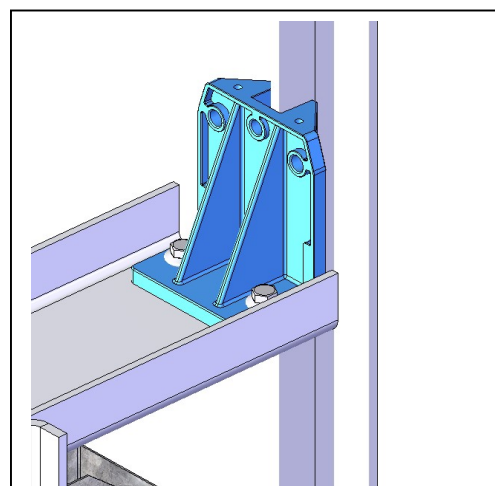
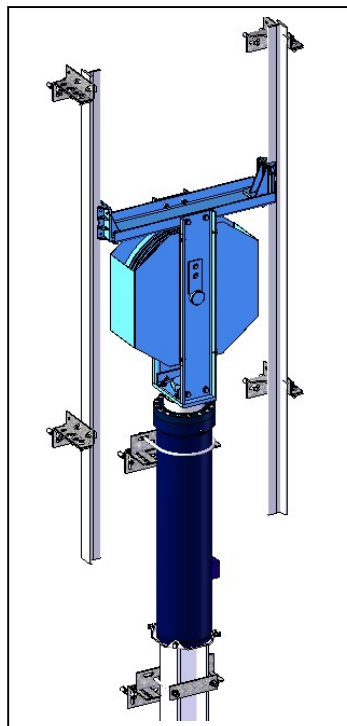

GUIDE SLIDERS	
BOLT DIN 6921 M12x40	2 uds
NUT DIN 6923 M12	2 uds

The position of the clamp brackets can be adjusted in the direction of the cross member, as shown in the picture above.

2.8. Montaje de los Amortiguadores de Foso.

Se instalarán 2 amortiguadores de foso en la posición indicada en el plano de replanteo del pedido.

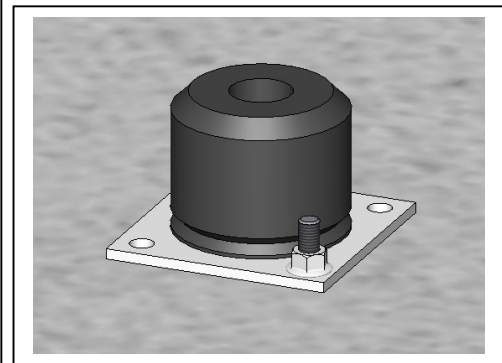
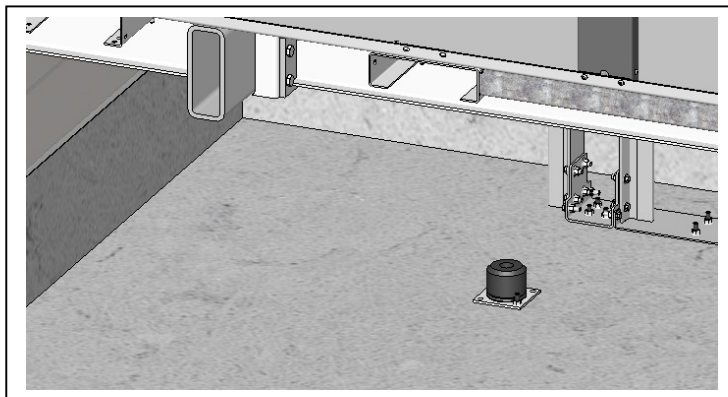
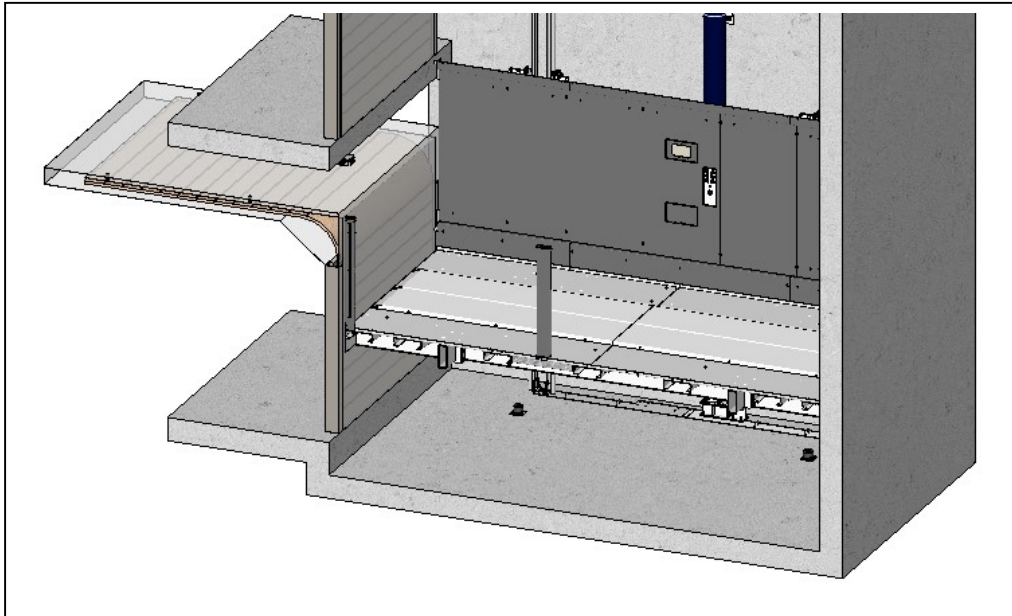

FIJACIÓN DEL AMORTIGUADOR	
TACO HILTI M12x100	2 uds
TUERCA DIN 6923 M12	2 uds

3. CAR FRAME

3.1. Vertical Beams Installation

Once the first section of cab rails has been installed in the pit, insert the "beams" corresponding to the cab chassis into the rails (to be assembled on site, assembled from the factory).

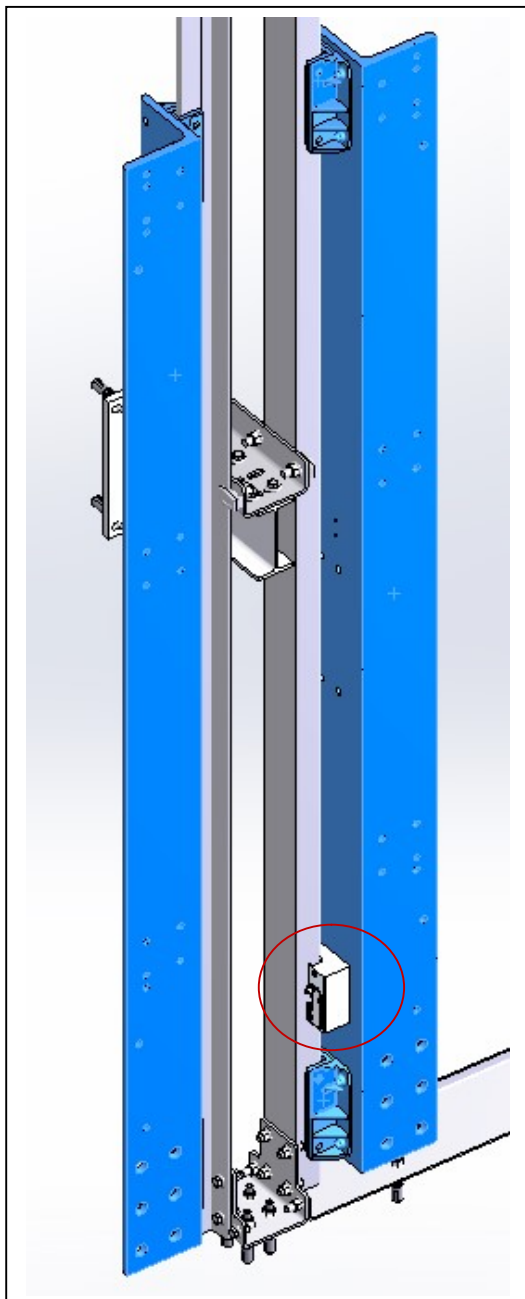

LEFT BEAMS

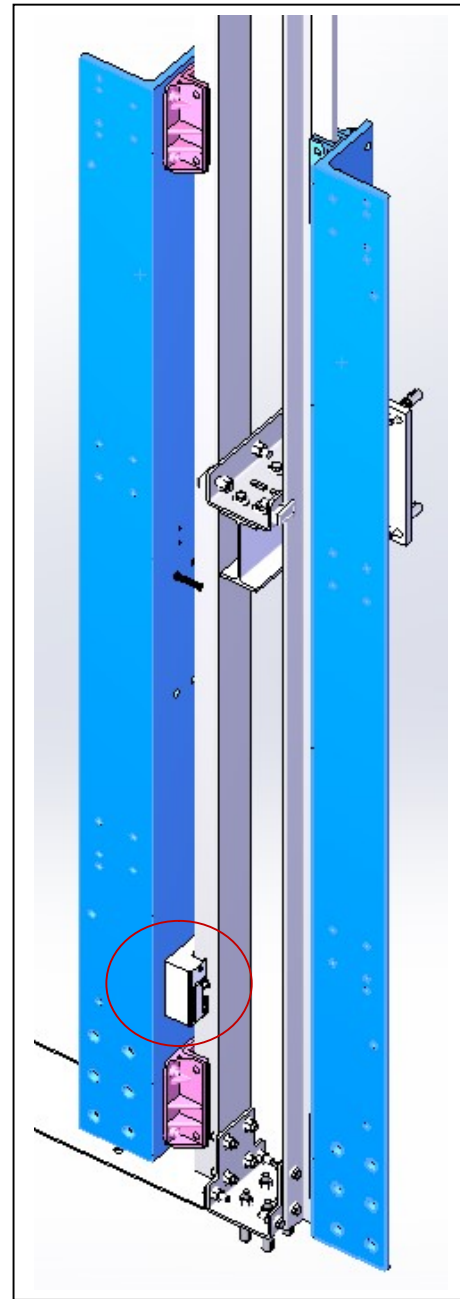

RIGHT BEAMS



IMPORTANT: Observe the inner position of the spar where the parachute is installed..

3.2. Installation of limit switch, and magnets detectors

LIMIT SWITCH	
BOLT DIN 912 M5x55	4 uds
NUT DIN 6923 M5	4 uds

MAGNET DETECTORS	
BOLT DIN 7380 M8x15	4 uds



IMPORTANT: Once the limit switch has been positioned, position the drive shoe.

3.3 Assembly of the cross plates of the longitudinal beams.

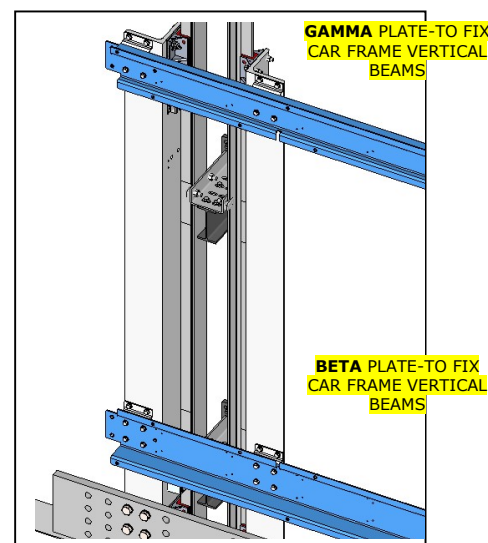
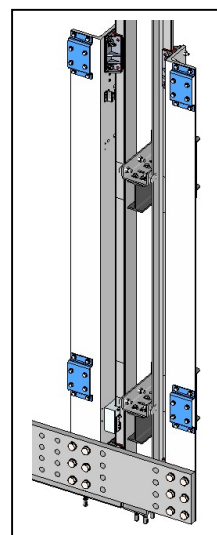
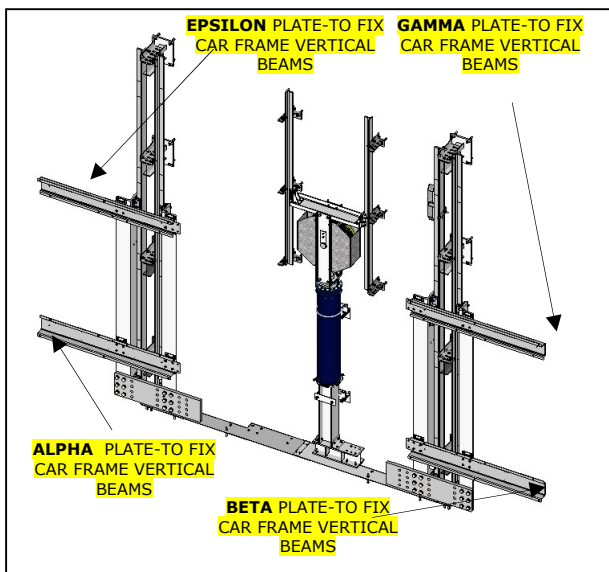



IMPORTANT: The beam connection plates are mounted on supplementary plates..

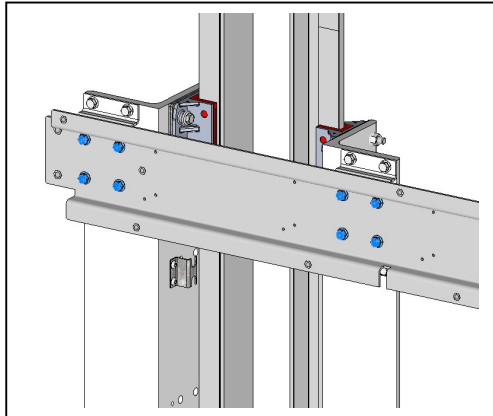

Alpha/Beta/Gamma/Epsilon SCREWS	
SET DIN 6921 M10x55	16 uds

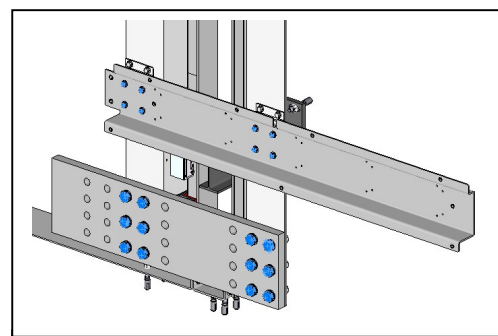
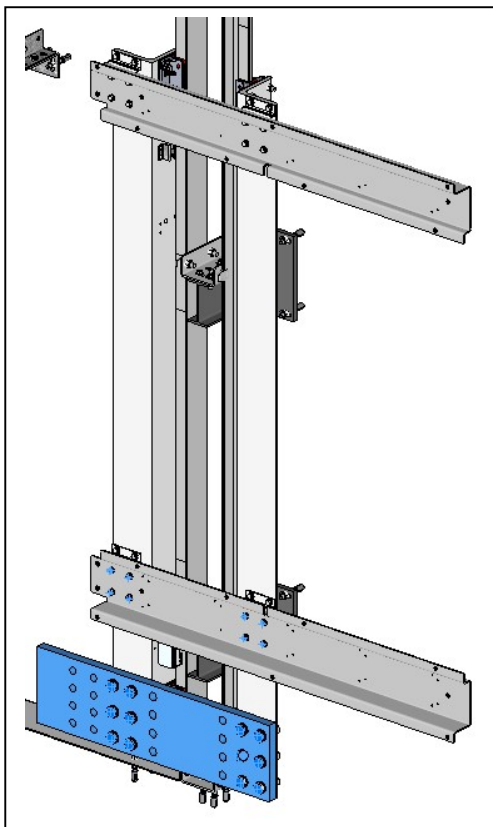

MAIN BEAD PLATE TO CAR FRAME BEAMS	
BOLT DIN 6914 M20x75	12 uds
NUT DIN 6915 M20	12 uds
WASHER DIN 6916 DIA. 21	12 uds

3.4. Installation of the traction Beam.

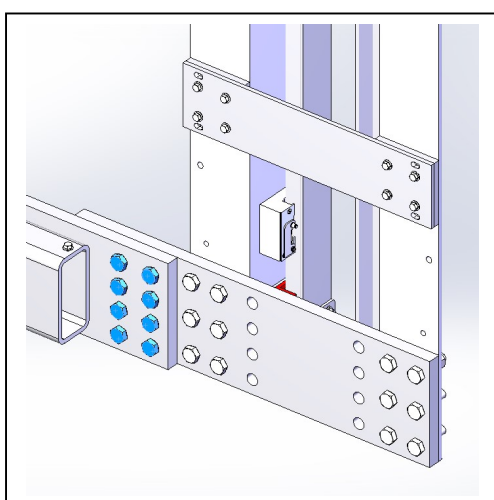
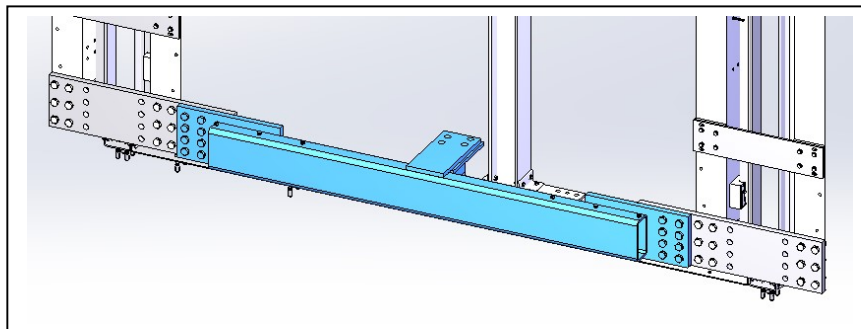

TRACTION BEAM

BOLT DIN 6914 M20x95	16 uds
NUT DIN 6915 M20	16 uds
FLAT WASHER DIN 6916 DIA.	16 uds

3.5. Installation of the secondary car frame beams.

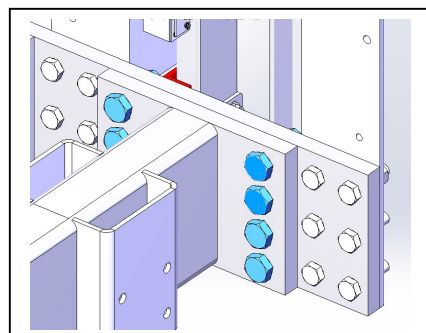
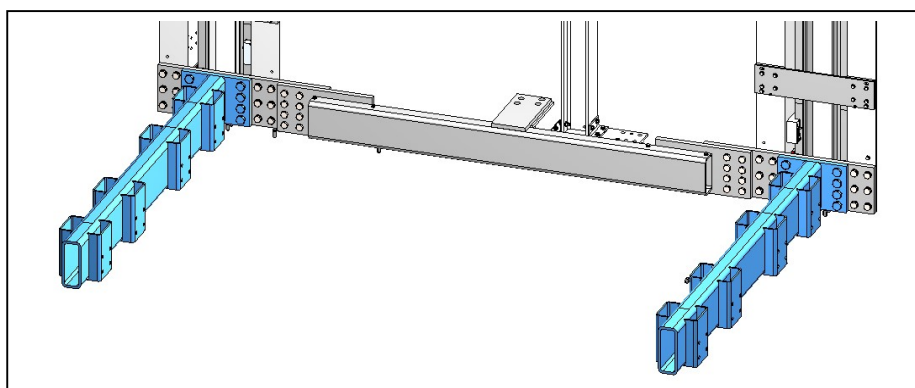

SECONDARY CAR FRAME BEAMS

BOLT DIN 6914 M24x95	16 uds
NUT DIN 6915 M24	16 uds
FLAT WASHER DIN 6916 DIA.	16 uds

3.6. Installation of the internal crossing secondary beams.

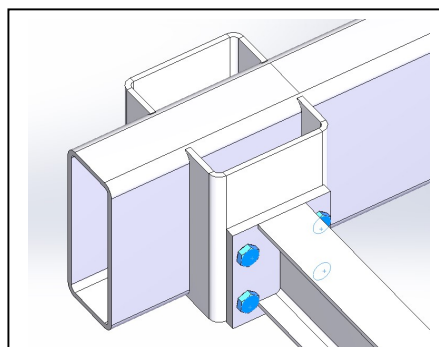
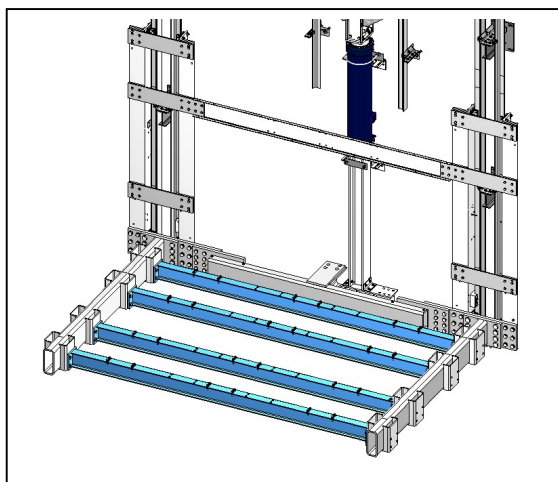

INTERNAL CROSSING SECONDARY BEAMS	
BOLT DIN 6914 M16x50	4 uds
NUT DIN 6915 M16	4 uds
WASHER DIN 6916 DIA. 17	4 uds

3.7. Installation of the external crossing secondary beams.

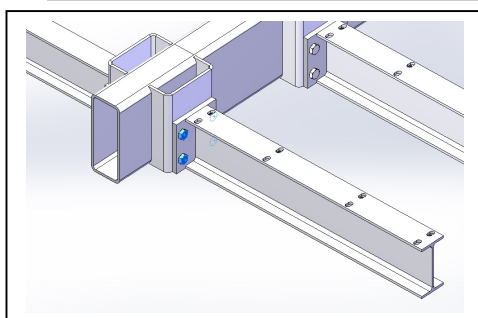
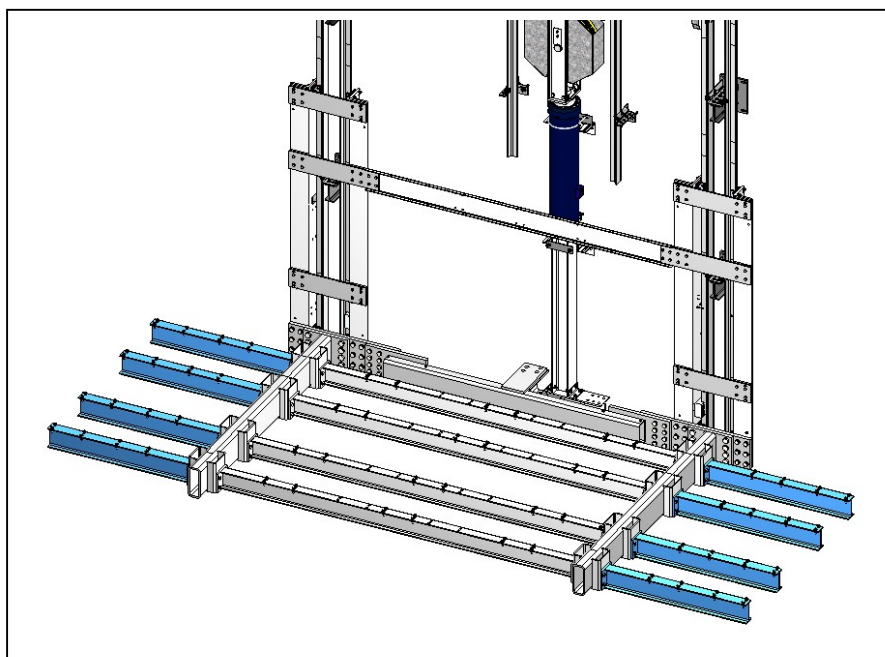

EXTERNAL CROSSING SECONDARY BEAMS	
BOLT DIN 6914 M16x50	4 uds
NUT DIN 6915 M16	4 uds
WASHER DIN 6916 DIA. 17	4 uds

3.8. Installation of the internal car frame bed profiles.

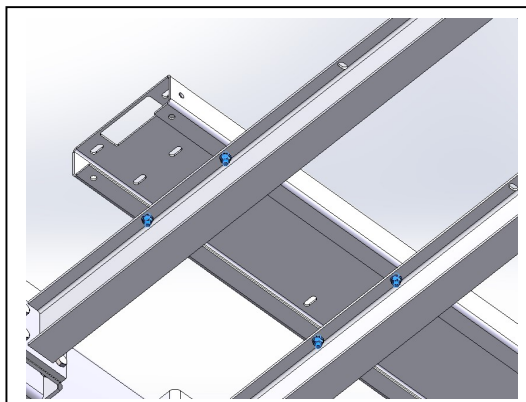
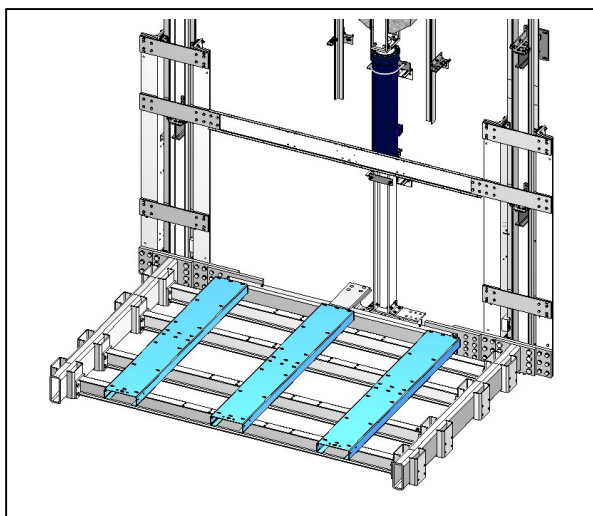

INTERNAL CAR FRAME BED PROFILES

BOLT DIN 6921 M12x35	20 uds
NUT DIN 6923 M12	20 uds

3.9. Installation of the external car frame profiles.

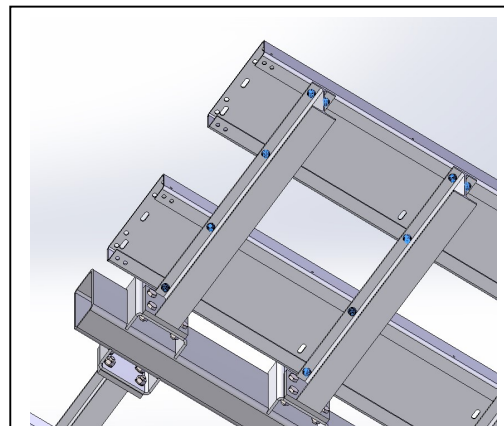
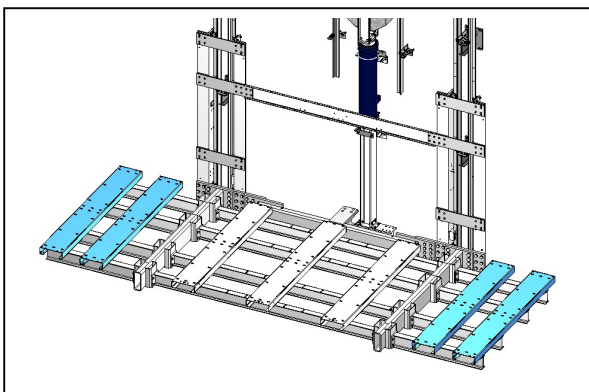

EXTERNAL CAR FRAME PROFILES

BOLT DIN 6921 M12x40	16 uds
NUT DIN 6923 M12	16 uds

3.10. Installation of the front car frame profile.

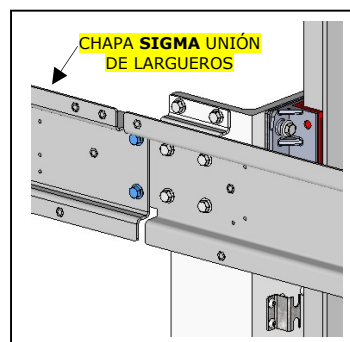
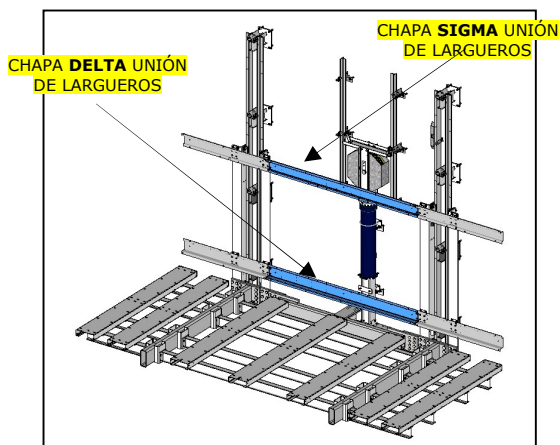

FRONT CAR FRAME PROFILE (DELTA+SIGMA)

BOLT DIN 6921 M10x30	8 uds	
NUT DIN 6923 M10	8 uds	

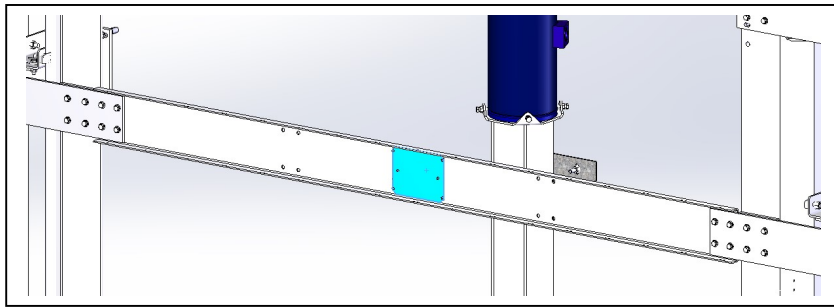

Board connection plate

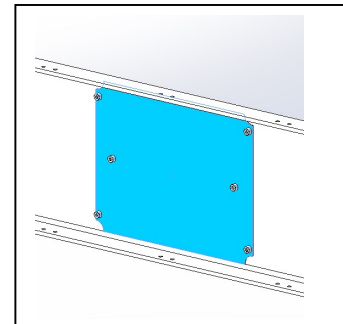

BOARD CONNECTION PLATE

BOLT DIN 912 M4x16	6 uds
NUT DIN 6923 M4	6 uds

3.11. Installation of safety gear car frame fixation plates

These plates shall be screwed directly onto the pipe..

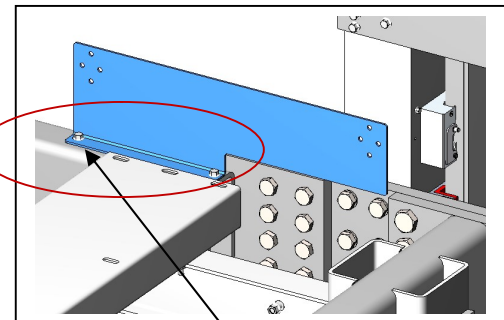
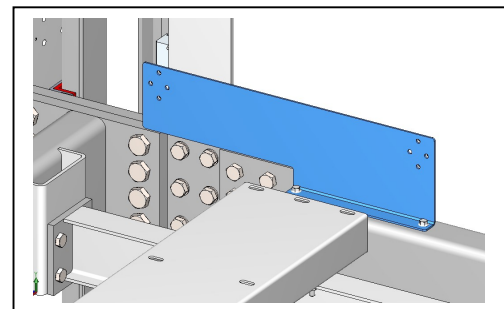
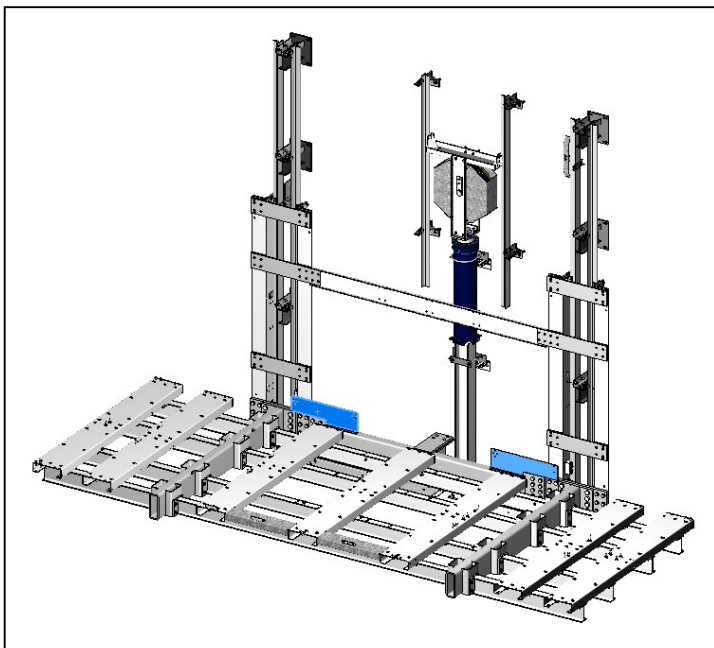

Screw directly onto the tube

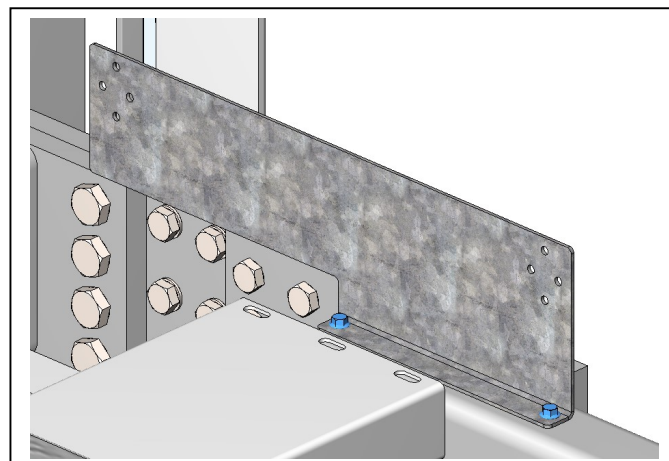

Safety gear Car frame fixation plates

BOLT DIN 6921 M10x20	2 uds
----------------------	-------

3.12. Installation of steel floor rail

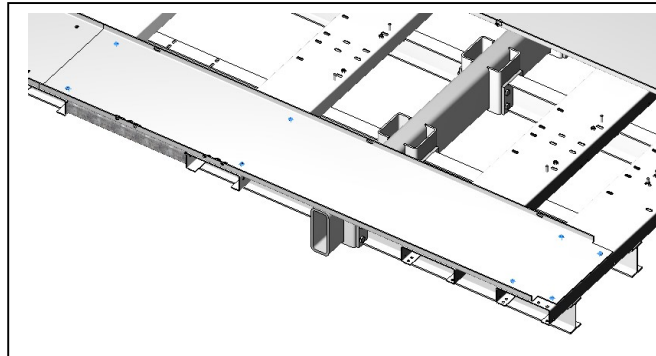
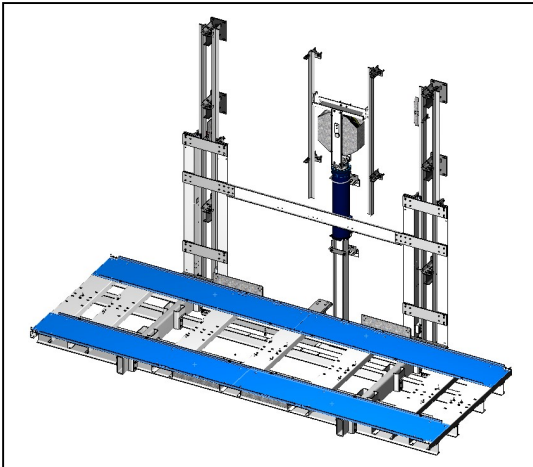

STEEL FLOOR RAIL

BOLT ISO 7380 M12x25	8 uds
NUT DIN 6923 M12	8 uds

3.13. Installation of ribbed steel floor right rails.

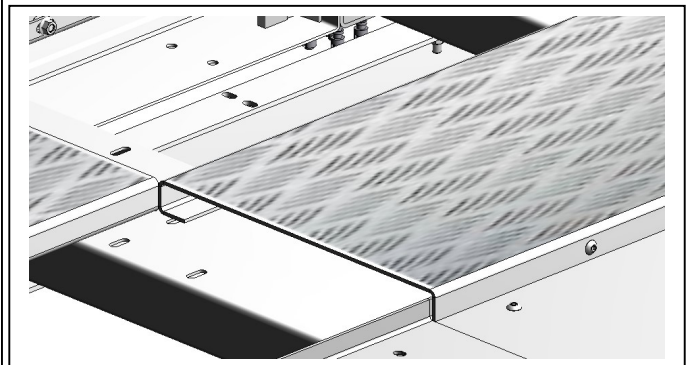
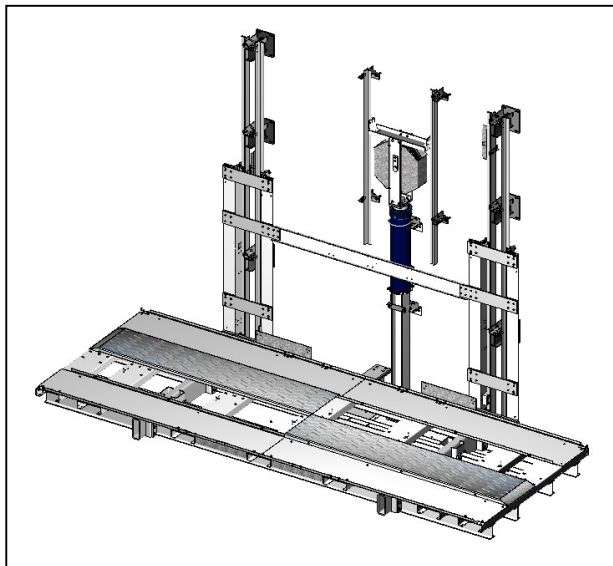

There are 4 central ribbed plates, two units in the right-hand position and two units in the left-hand position. The anchoring and fastening of the 4 plates is the same and is shown below.

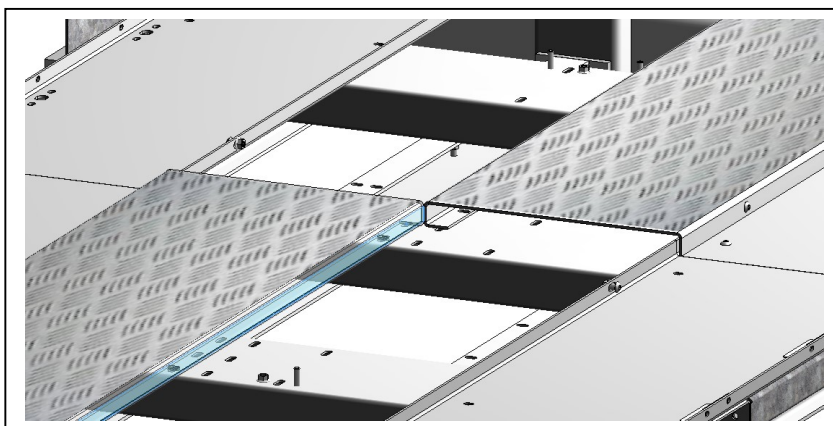

3.14. Installation of ribbed steel floor left rails.

The central ribbed plates (left and right) are attached to the chassis by means of base fastening bolts and side fastening bolts. The attachment to the base is carried out as follows.

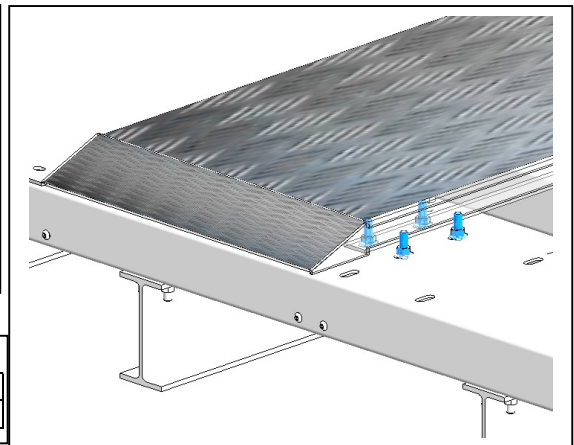
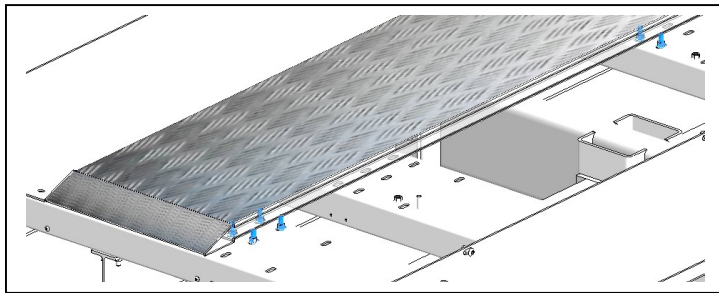
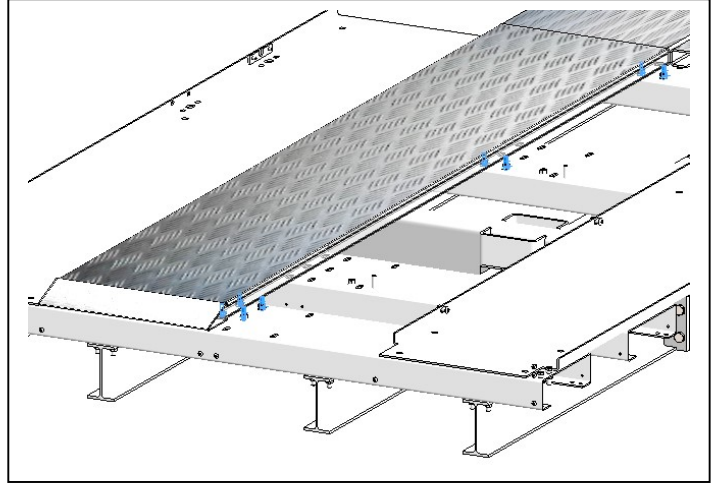
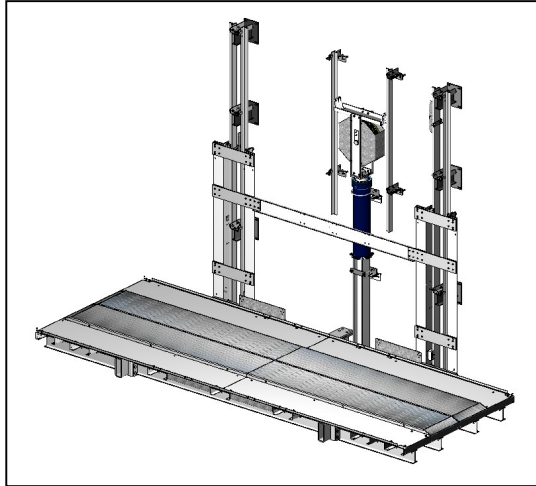

Fixation with the floor		
BOLT DIN 6921 M12x40	8 uds	
NUT DIN 6923 M12	8 uds	

Lateral fixation is carried out as follows.

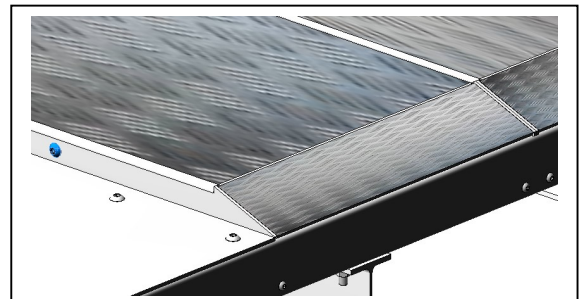
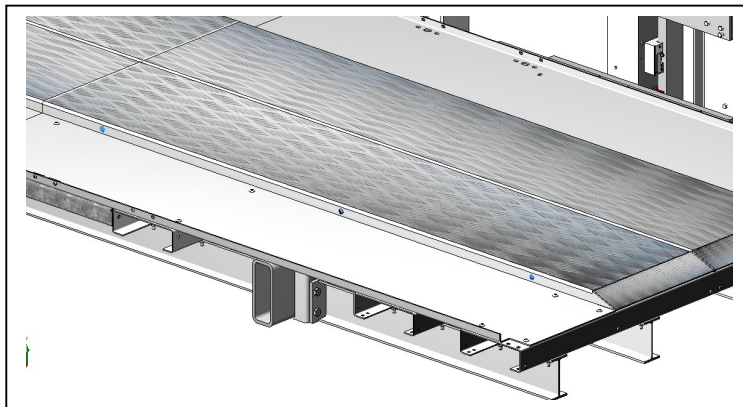

Lateral fixation		
BOLT ISO 7380 M12x40	3 uds	
NUT DIN 6923 M12	3 uds	

4. INSTALLATION OF SAFETY GEAR TRANSMISSION BAR.

4.1. Installation of Safety Gear Transmission bar.

The rudder drive rod shall be supplied in three parts.

The two outer parts consist of a 15 mm solid square bar and the inner part consists of an outer 21 mm square tube into which the 15 mm bars shall be inserted.

The telescopic assembly shall be adapted to the length required by the separation distance of the chutes..

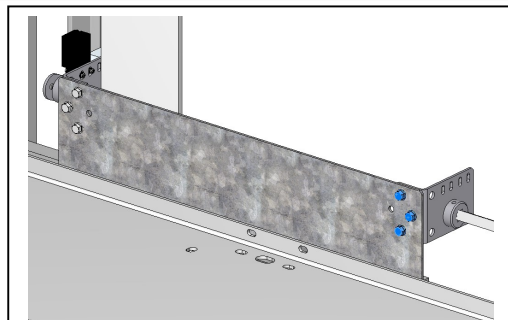
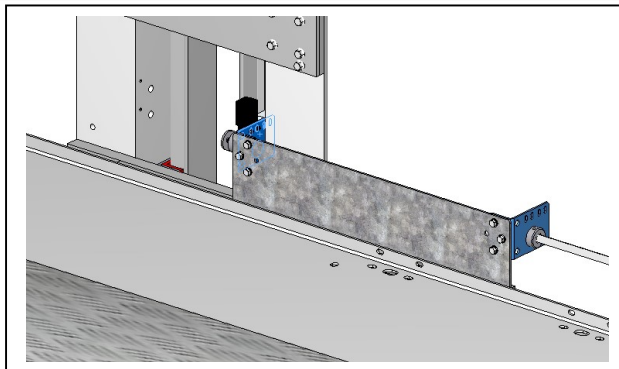
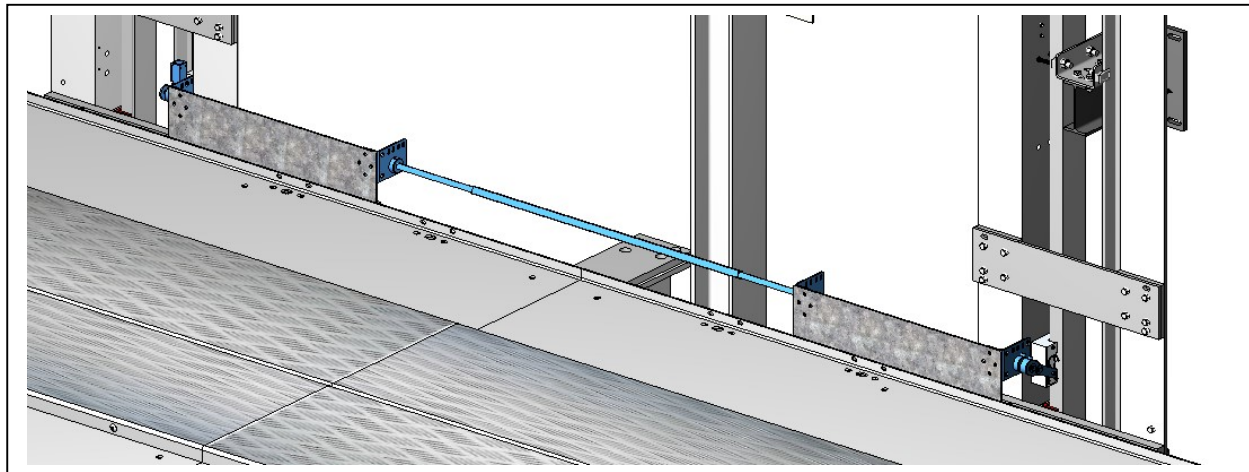

INTERNAL ANGLES

BOLT DIN 6921 M8x25	3 uds
NUT DIN 6923 M8	3 uds

EXTERNAL ANGLES

BOLT DIN 6921 M6x16	1 ud
---------------------	------

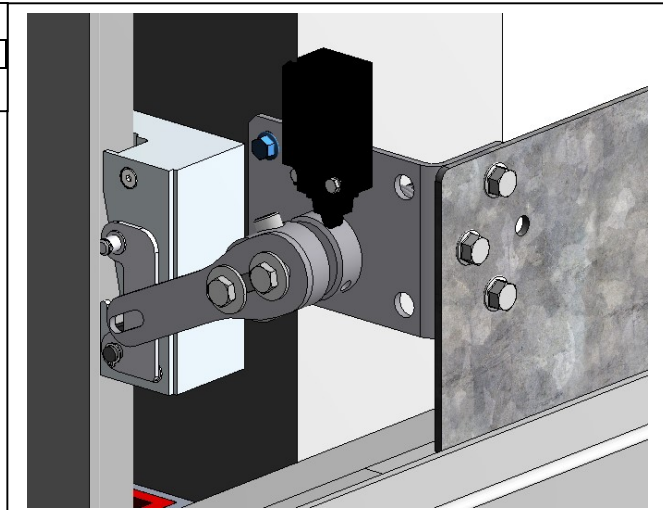

4.2. Installation of safety gear lever

The operation of the safety gear, in the event of cable slack, shall be carried out by operating the assembly formed by the two parts shown in the following image. The operation shall be carried out by means of a 6.5 mm diameter cable.

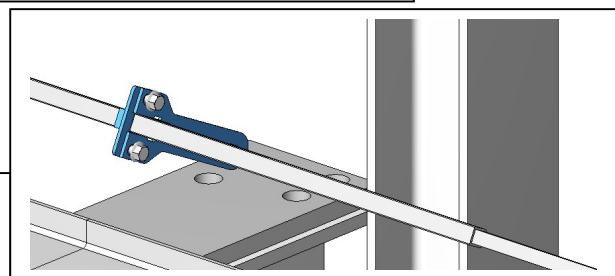
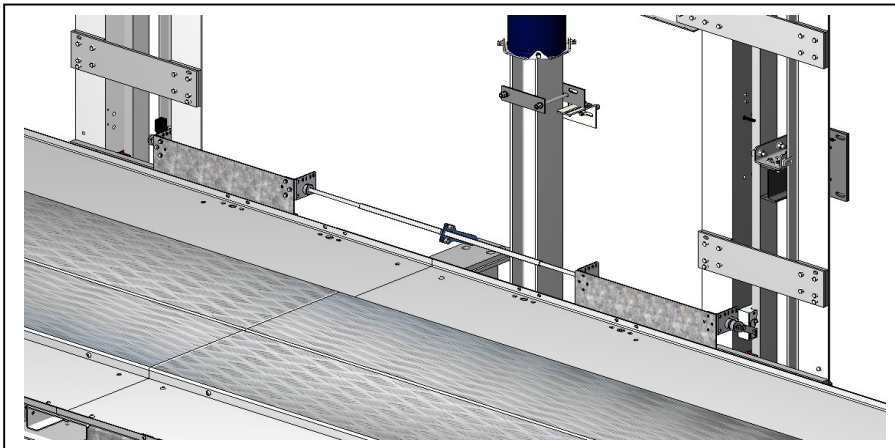

LEVER		
BOLT DIN 6921 M10x20		2 uds
NUT DIN 6923 M10		2 uds

5. INSTALLATION OF SKIRTING BOARD AND LINTEL

5.1. Installation of the 2 Skirting.

The skirting board is supplied in two sections: right and left skirting board. Both skirting boards are fixed in the same way.

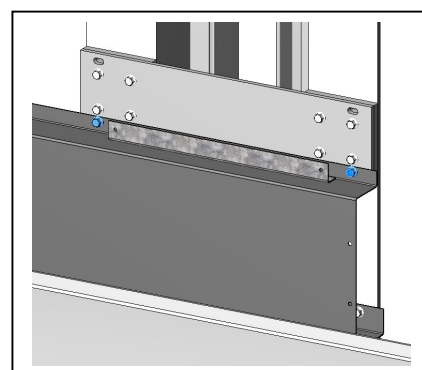
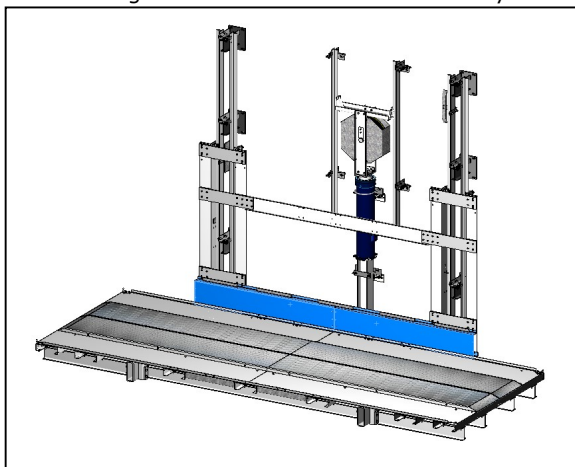

RIGHT SKIRTING BOARD		
BOLT DIN 6921 M10x55		2 uds
NUT DIN 6923 M10		2 uds

The skirting board shall be closed by means of a cover plate which is screwed to the skirting board by means of a corner plate. The screws are screwed directly into the corner plate.

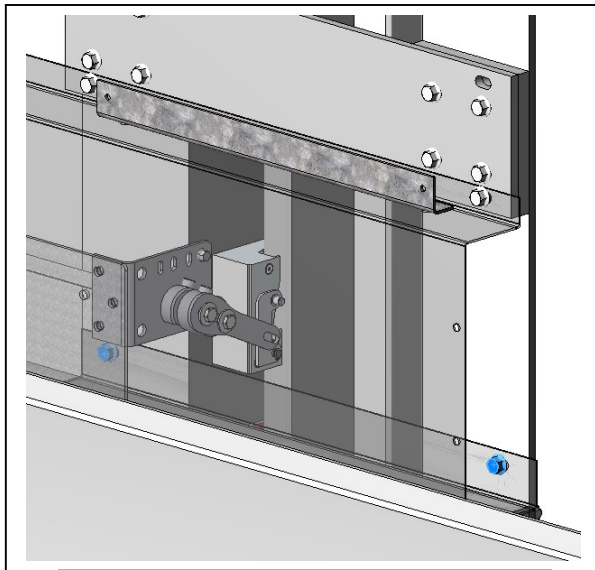

RIGHT SKIRTING BOARD	
BOLT DIN 6921 M10x35	2 uds
NUT DIN 6923 M10	2 uds

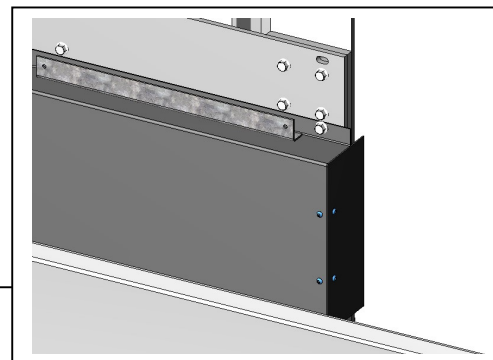
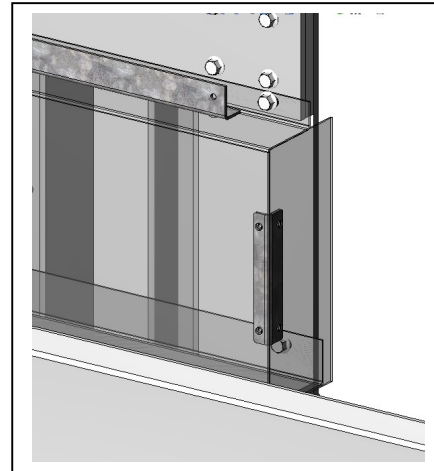

RIGHT SKIRTING BOARD COVER	
BOL ISO 7380 M6x10	4 uds

This action will have to be repeated with the left skirting board.

The fixing between the left and right skirting boards is done by means of a fixing bracket, as shown in the attached picture. The screws are screwed directly into the fixing bracket.

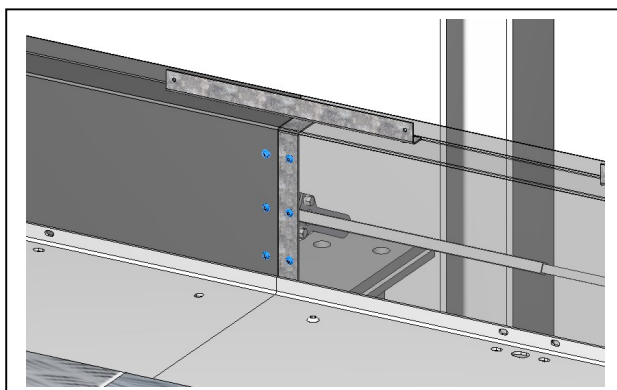
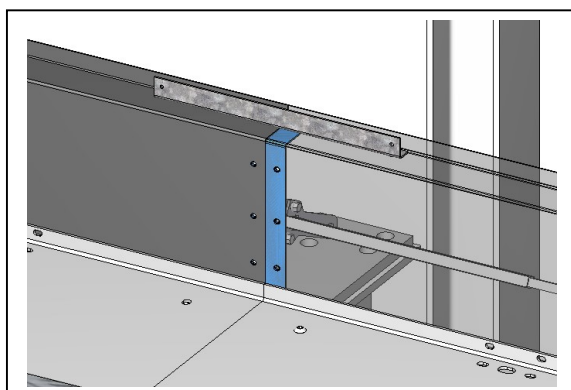

SKIRTING BOARD ANGLE FIXATION	
BOLT ISO 7380 M8x10	6 uds

5.2. Assembly of the front shelf support brackets on the skirting board..

5 brackets shall be mounted to support the 5 front trays.

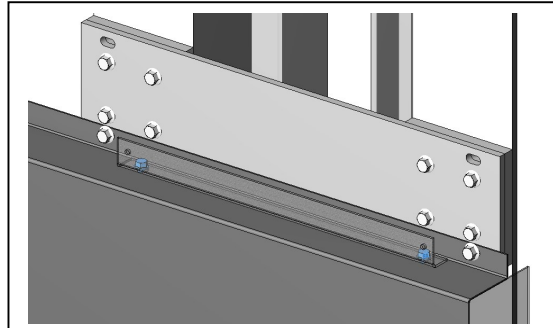
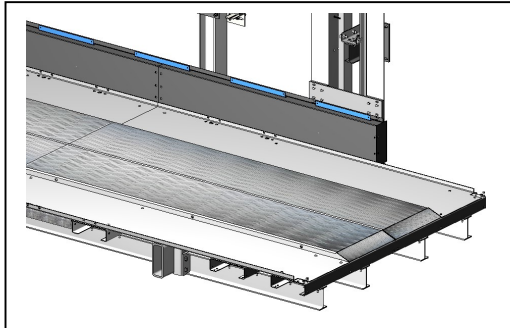

ANGLES FRONTS COVER

TORNILLO DIN 6921 M8x25	2 uds
TUERCA DIN 6923 M8	2 uds

5.3. Installation of lintels

The lintel is supplied in two sections: right lintel and left lintel.
Both lintels are fixed in the same way.

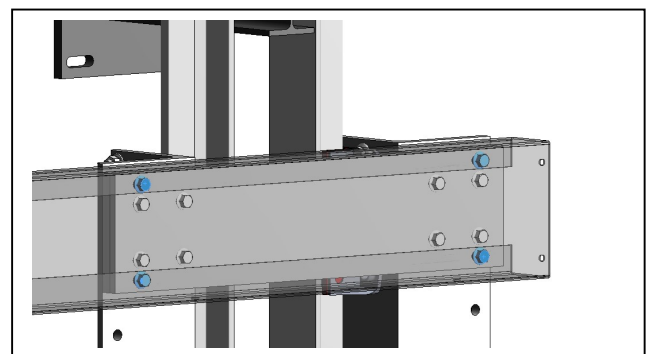
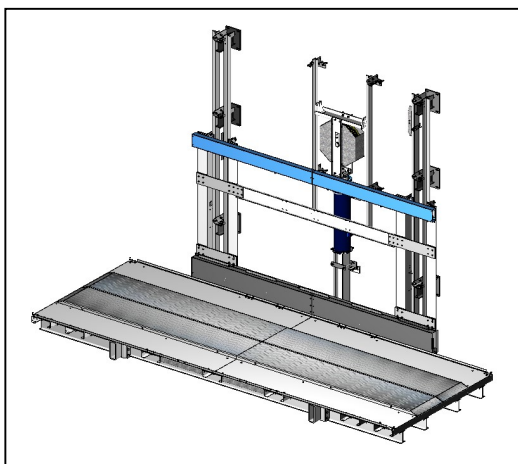

RIGHT LINTEL

BOLT DIN 6921 M10x55	4 uds
NUT DIN 6923 M10	4 uds

The lintel is closed by means of a cover plate which is screwed to the lintel by means of a corner plate.
The screws are screwed directly into the corner plate..

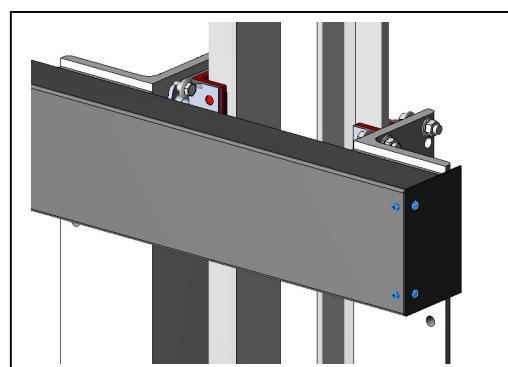
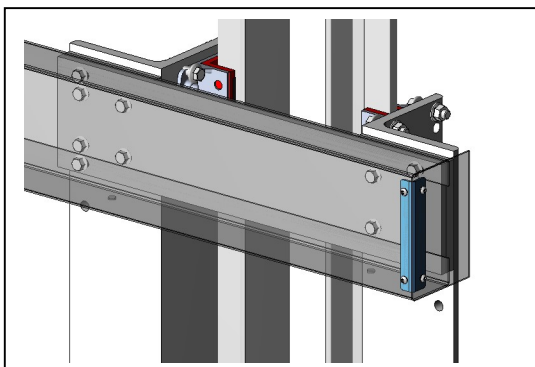

RIGHT LINTEL COVER

BOLT ISO 7380 M6x10	4 uds
---------------------	-------

This action will have to be repeated for the left skirting board.

The fastening between the left and right lintels is done by means of a fastening bracket, as shown in the attached picture. The screws are screwed directly into the fixing bracket.

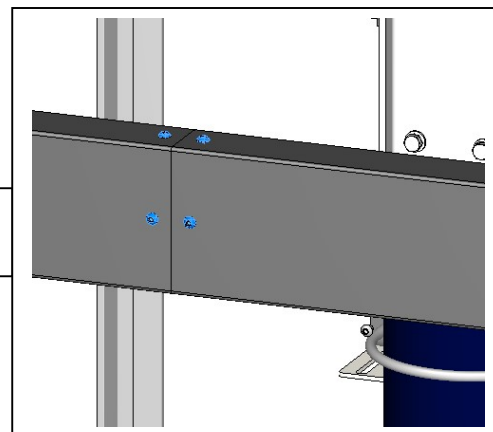
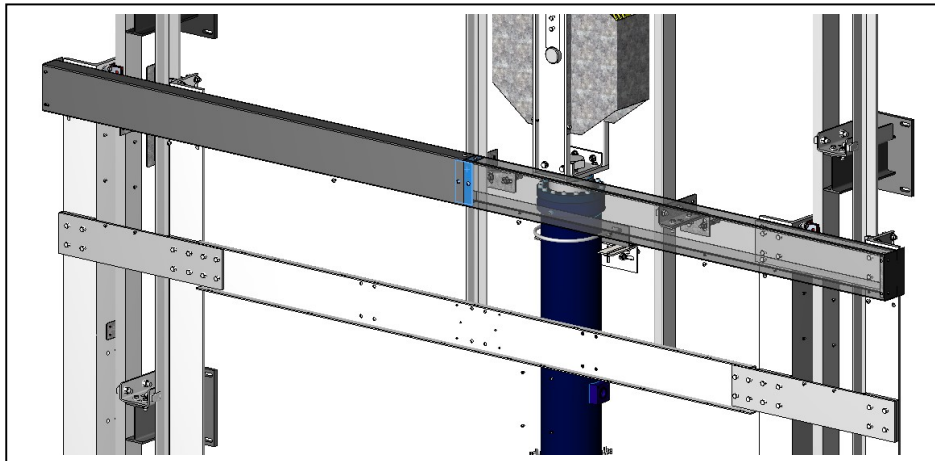

LINTEL ANGLES	
BOLT ISO 7380 M8x10	4 uds

5.4. Mounting of the front shelf support brackets on the lintel.

5 brackets shall be mounted to support the 5 front trays.

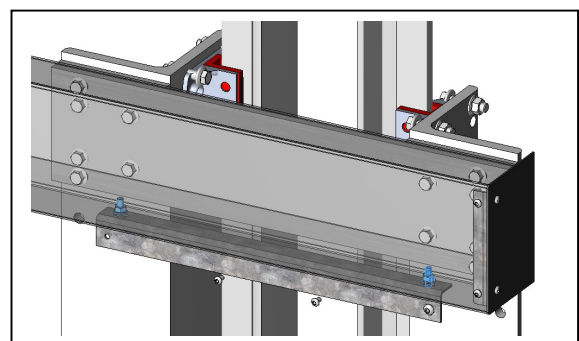
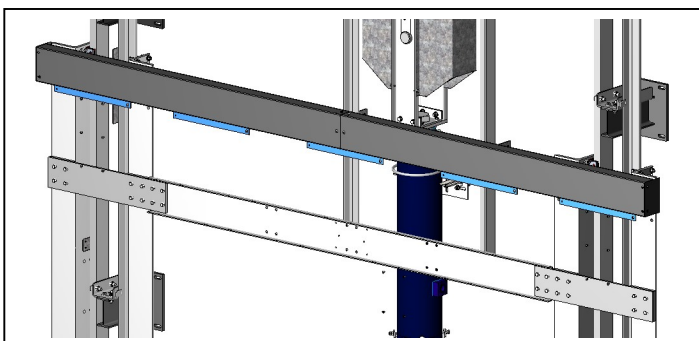

FRONT ANGLES	
BOLT DIN 6921 M8x25	2 uds
NUT DIN 6923 M8	2 uds

6. ASSEMBLY OF THE FRONT PLATES.

6.1. Mounting of the outer front shelves.

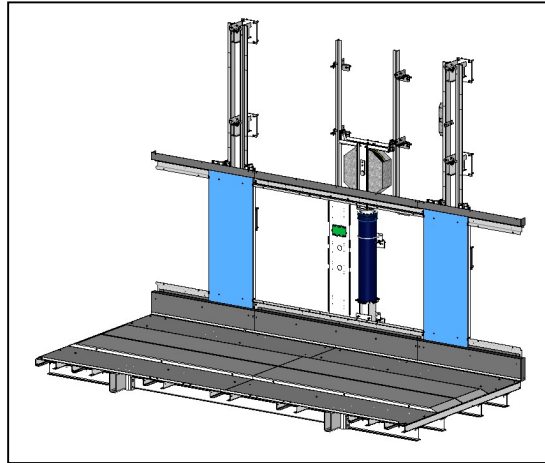

The front panels shall be screwed directly onto the corners attached to the skirting board and lintel..

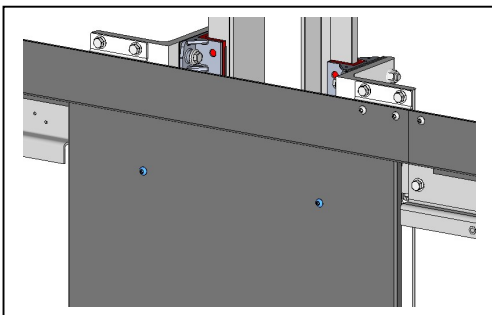

EXTERNAL FRONT PANELS	
BOLT ISO 7380 M8x10	4 uds



The front trays have a window for the location of light signalling elements.
In the event of not having these elements, a plate shall close the hole provided..

Front small plates	
BOLT ISO 7380 M6x10	6 uds

6.2. Assembly of the inner front panels.

The front panels shall be screwed directly onto the corners attached to the skirting board and lintel..

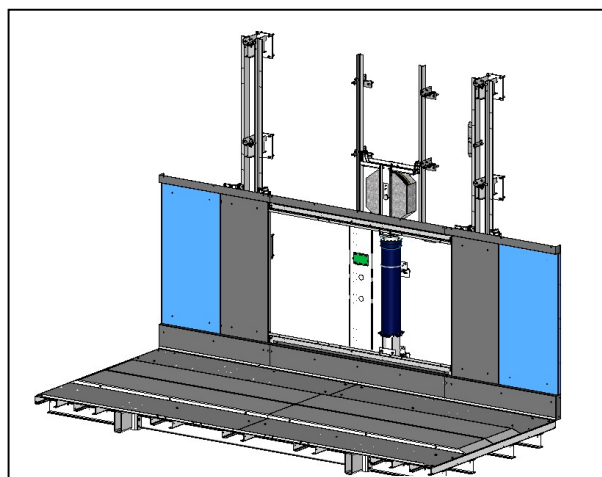

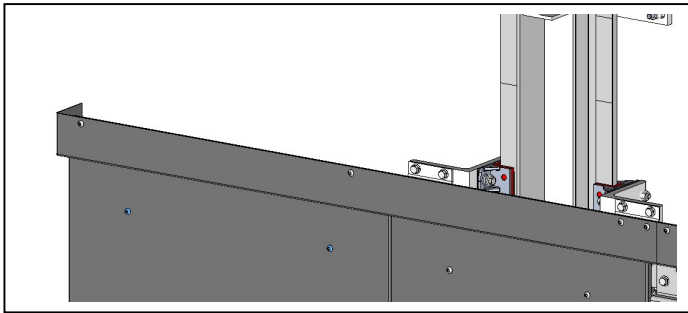

INNER FRONT PANELS	
BOLT ISO 7380 M8x10	4 uds

IMPORTANT: Make sure that the surfaces shown in the following image, which belong to the plinth and the external front plate, are on the same plane; this will guarantee the correct assembly of the photocell at a later date.

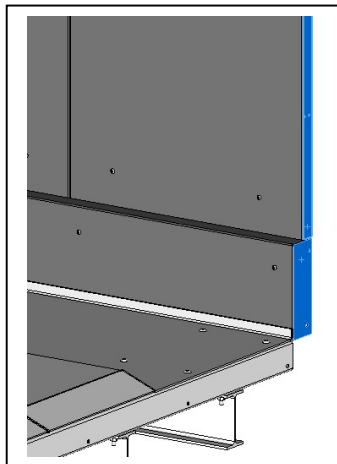

6.3. Assembly of the button PANEL.

The front panel is screwed directly onto the corners fixed to the skirting board and lintel. The front panel can be rotated 180° so that the button panel is either to the left half of the platform or to the right half, as shown in the following image.

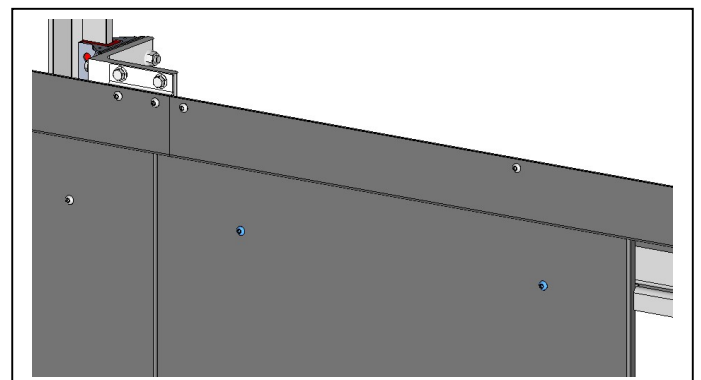
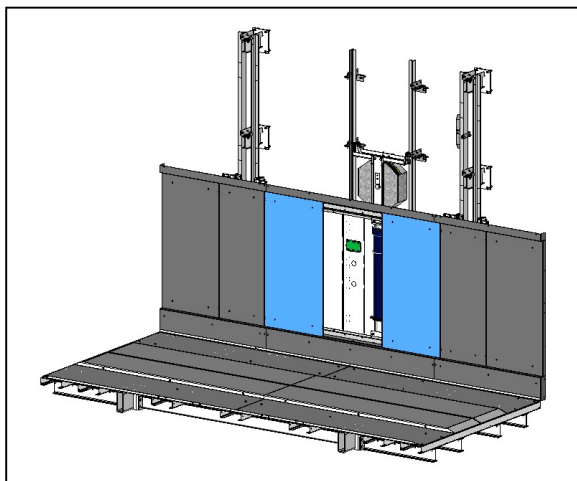

COP PANEL	
BOLT ISO 7380 M8x10	4 uds

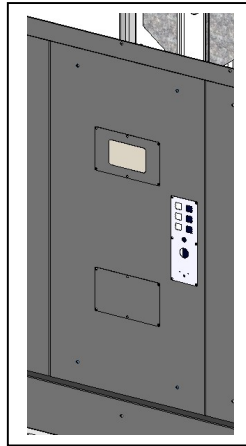
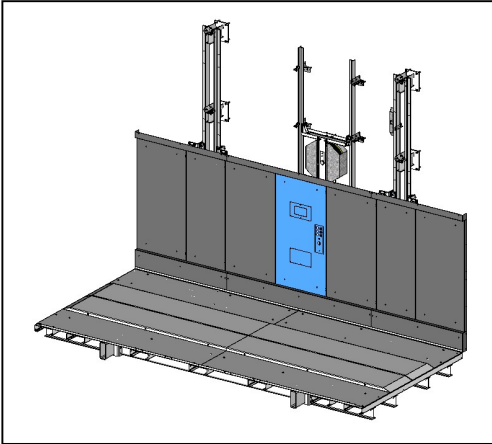

BUTTON PANEL	
BOLT ISO 7380 M6x10	6 uds

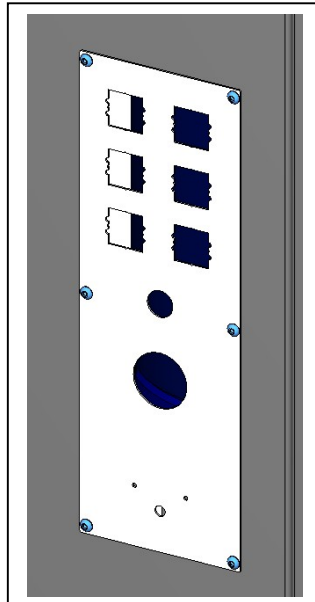
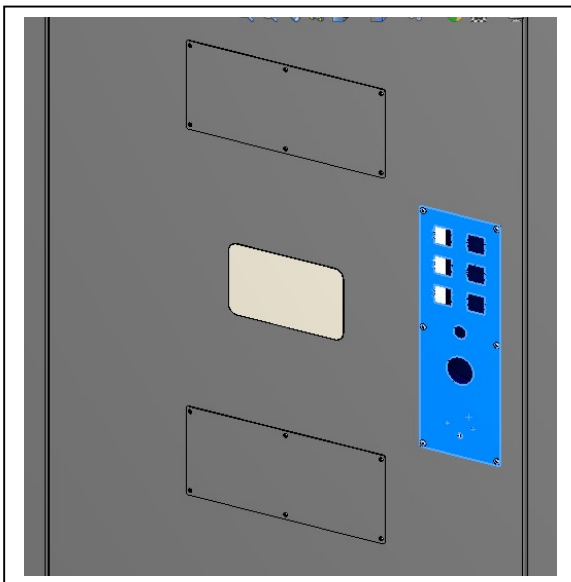

7. ASSEMBLY OF THE BUTTON POST.

7.1. Assembly of the button plate.

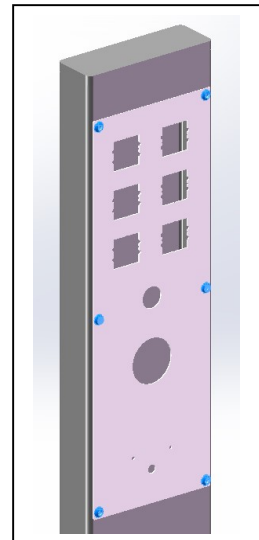
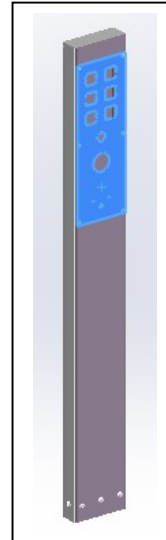
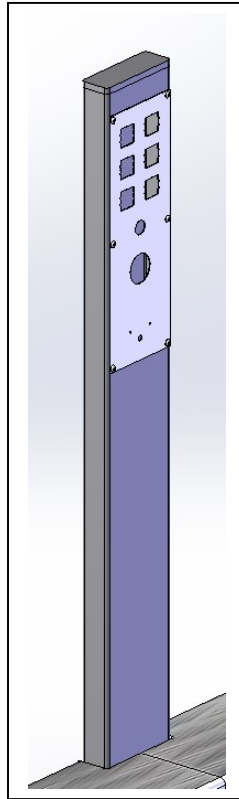
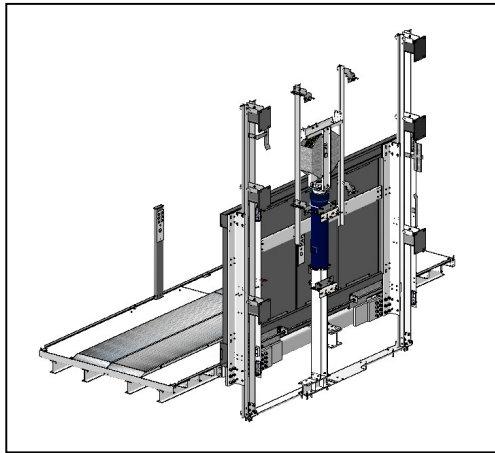

Assembly of the button plate
 BOLT ISO 7380 M6x10 6 uds

7.2. Fixing of the pushbutton tube to the Car Frame.

There are four possible locations for the pushbutton tube, depending on the position of the main boarding, one of the four positions must be selected.

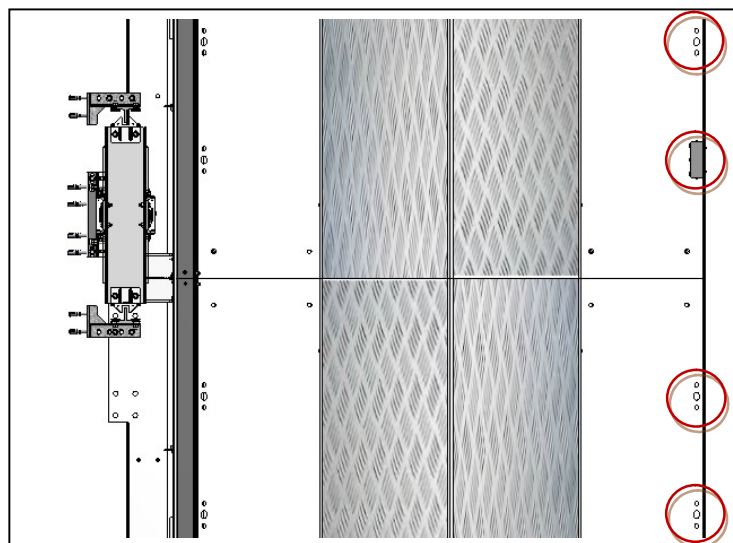

The button tube is supported on a plate which is screwed to the chassis, as shown in the following picture: Depending on the selected position of the push-button tube, the plate supporting the push-button tube is screwed either on the right half of the chassis or on the left half of the Car Frame.

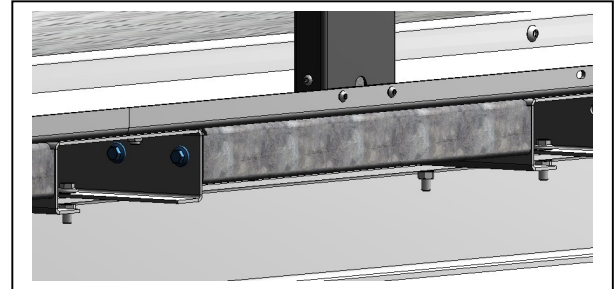
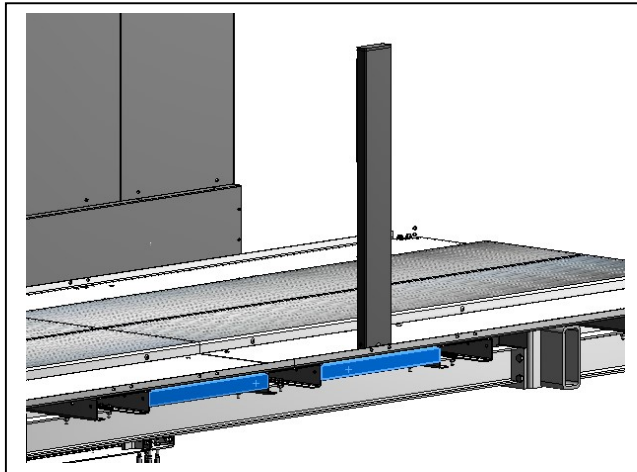

Pushbutton bed plate frame	
BOLT DIN 6921 M10x30	4 uds
NUT DIN 6923 M10	4 uds

Position the clamping plate of the push button tube as a spacer between the tube and the checker plate.

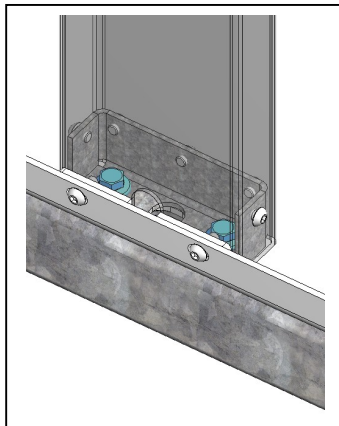

COP TUBE FIXATION	
BOLT DIN 6921 M12x35	2 uds
NUT DIN 6923 M12	2 uds

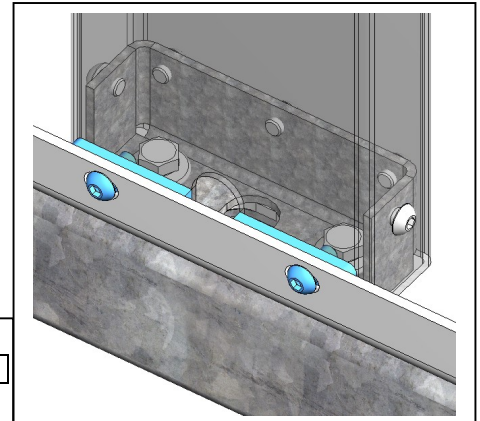

COP ANGLE	
BOLT ISO 7380 M8x20	2 uds

7.3. Assembly of the blind post cap.

Once the push button tube has been positioned, it is necessary to cover the other 3 possible positions and its 4 symmetrical positions located under the push button tray.

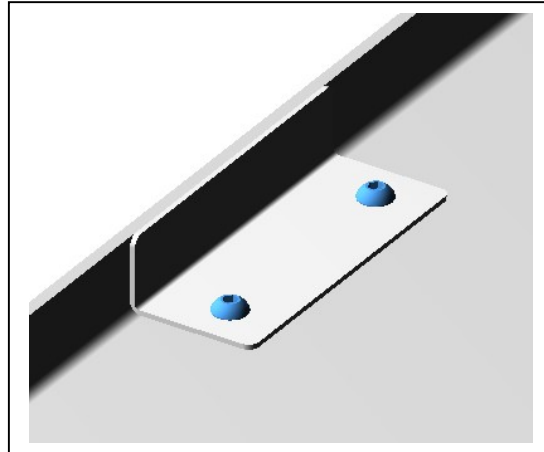
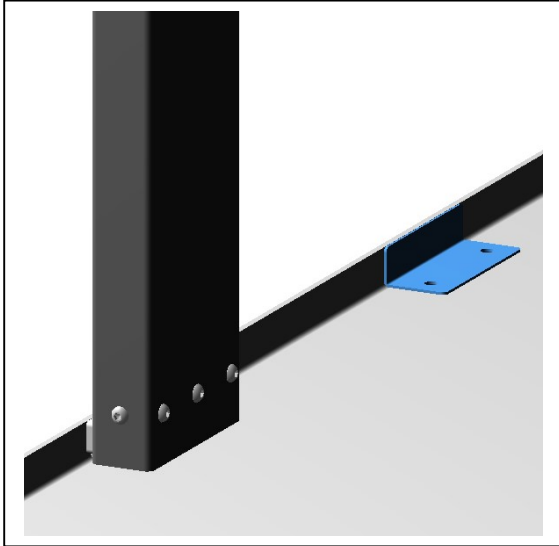

TUBE BLIND HOLE PLATE	
BOLT ISO 7380 M8x30	2 uds
NUT DIN 6923 M8	2 uds

8. ASSEMBLY OF THE PHOTOCELLS.

8.1. Positioning of the photocell tubes and line of coverage.

The image below shows the areas covered by the light curtains. As can be seen, the coverage at the bottom of the platform is external. This criterion should be taken into account when placing the photocell posts..

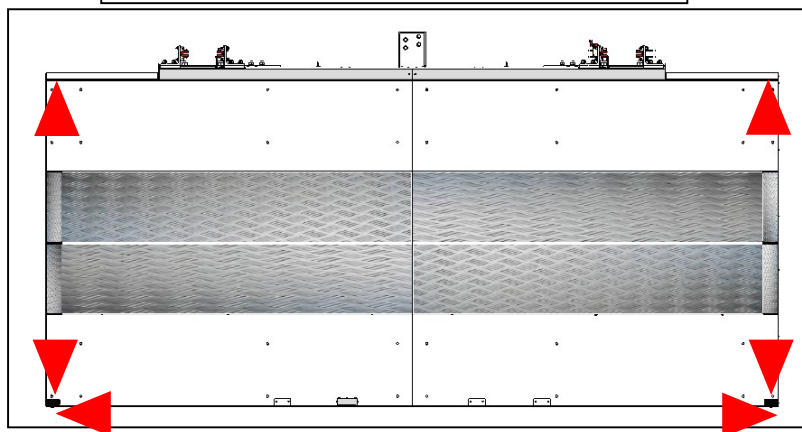
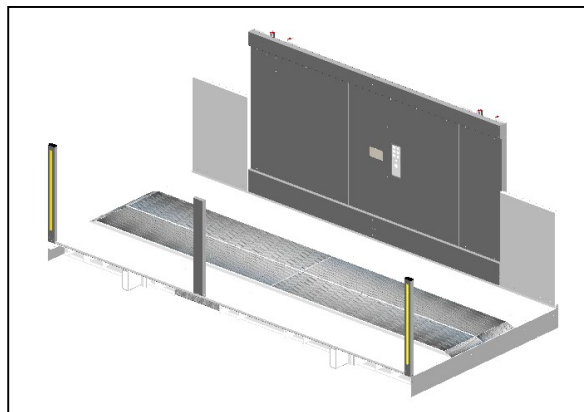

8.2. Positioning of the outer light curtains on the tube.

The light curtain is directly screwed to the tube..

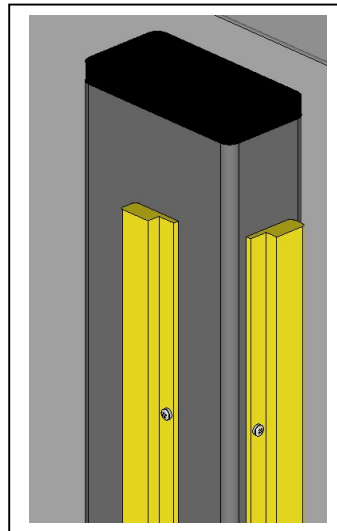
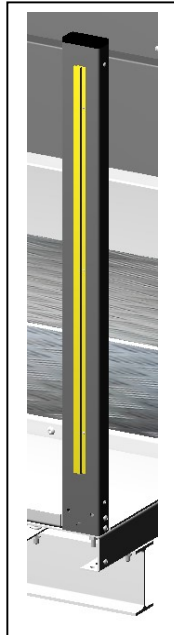

EXTERNAL PHOTOCELL	
BOLT ISO 7380 M3x8	3 uds

8.3. Positioning of the inner light curtains in the tube.

The inner light curtain is screwed onto a folded part, which in turn is screwed directly onto the tube. The light curtain is screwed directly to this plate.

! iIMPORTANT!:

The rectangular tube has been designed with symmetry to avoid the difficulties that could arise due to the existence of a weld bead inside the tube that could hinder the positioning of the folded part supporting the photocell curtain. In the event that the internal weld would hinder the positioning of the photocell support plate, rotate the tube 180°.

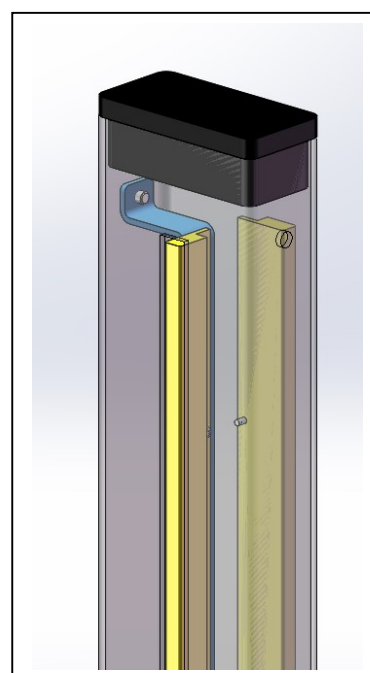
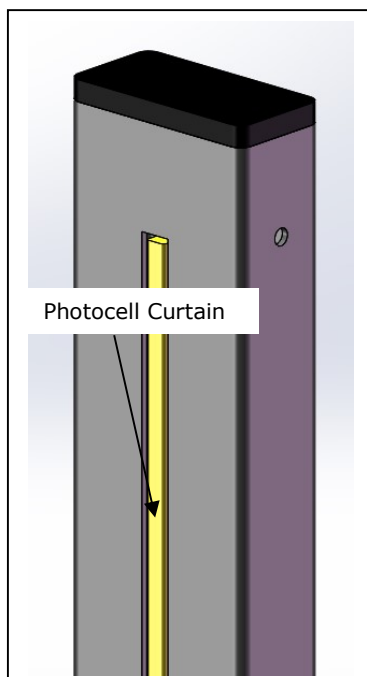

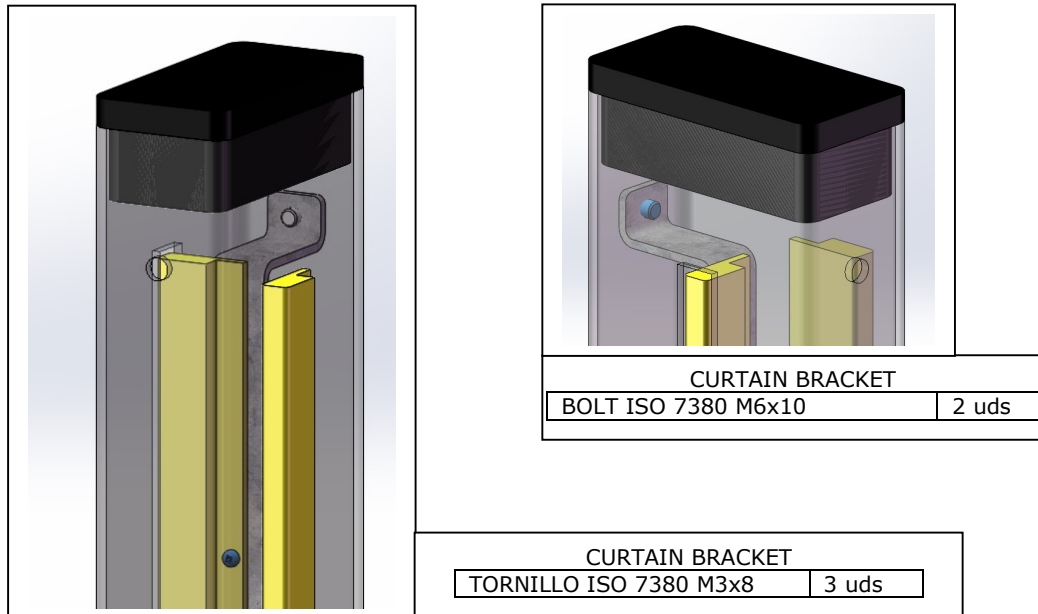

8.4. Attachment of the light curtain tubes to the chassis.

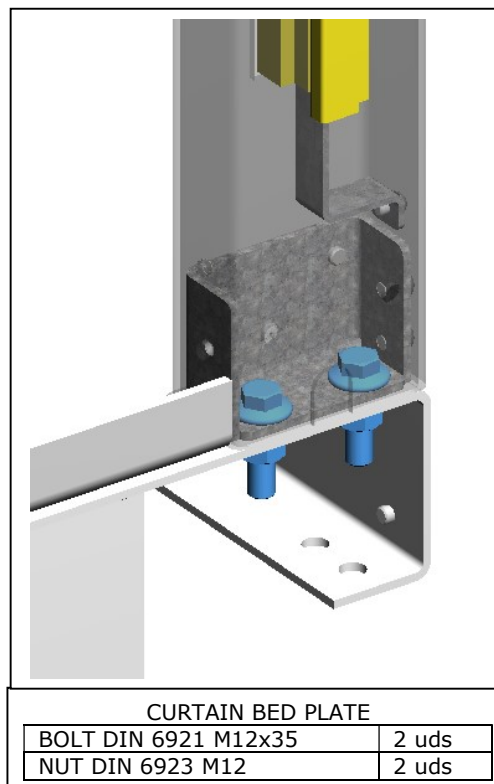

8.5. Safety plate installation.

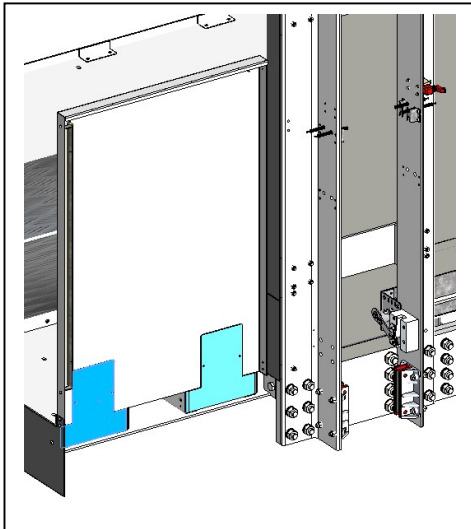

SAFETY PLATE	
BOLT DIN 6921 M8x35	4 uds
NUT DIN 6923 M8	4 uds

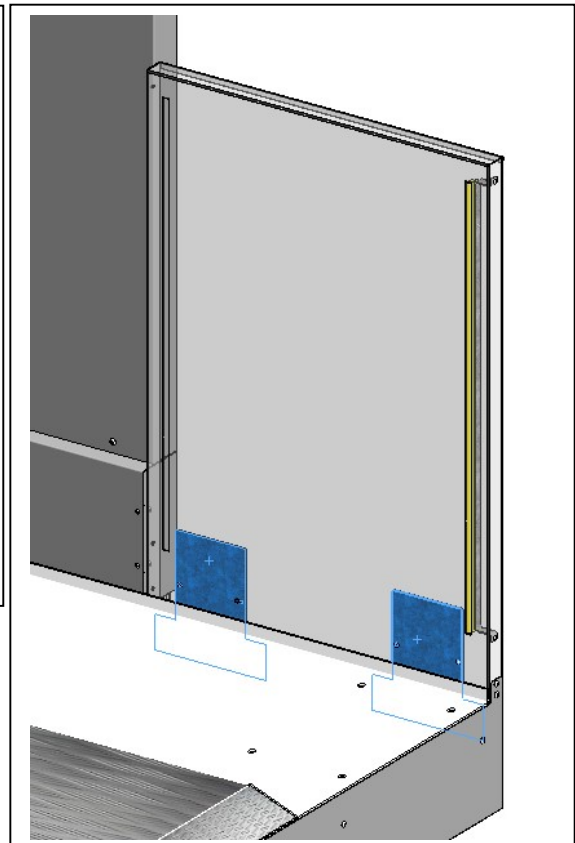
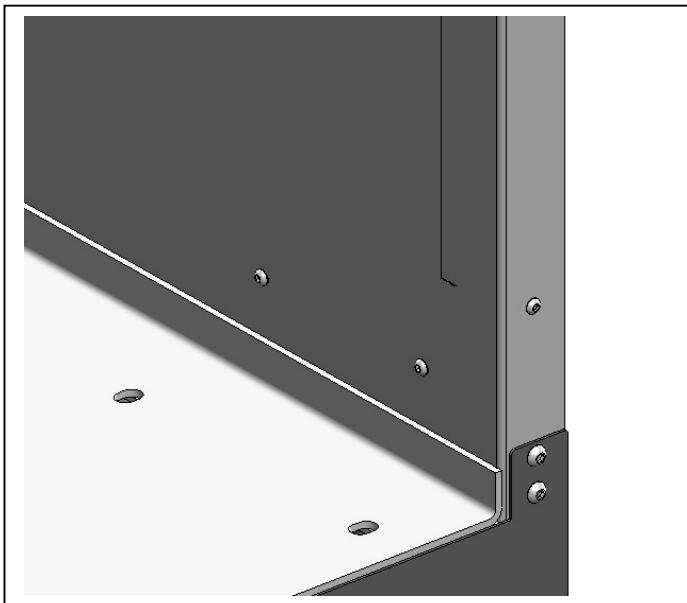

SAFETY BED PLATE	
BOLT DIN 7380 M6x20	4 uds
NUT DIN 6923 M6	4 uds

8.6. Fixation of the Curtain on the Safety plate

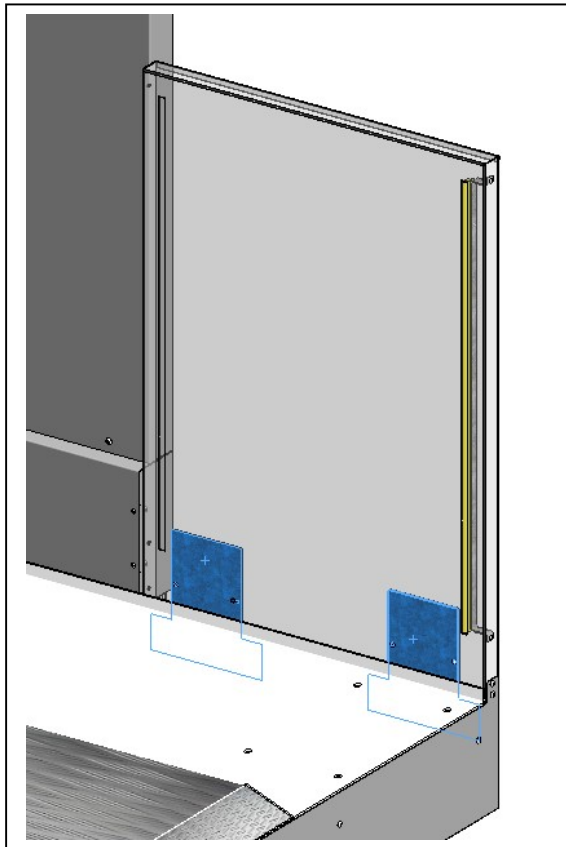

CURTAIN BRACKET	
BOLT ISO 7380 M6x10	2 uds

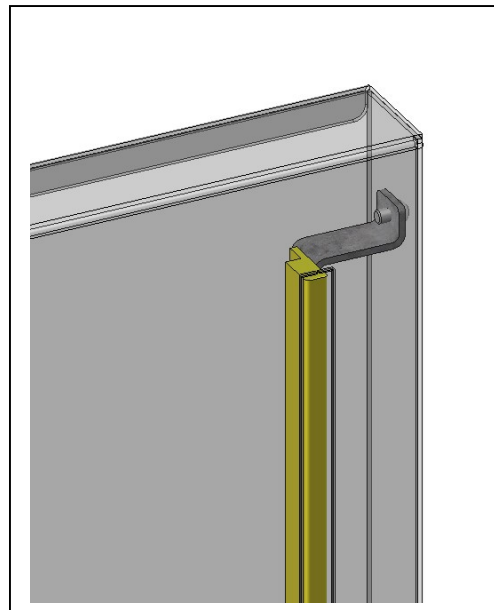

9. ASSEMBLY OF THE SKIRTS.

9.1. Assembly of the skirts.

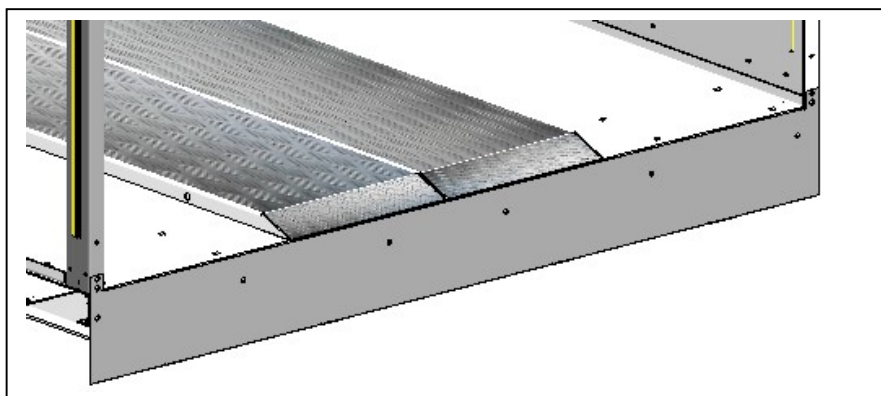

Assembly of the skirts.	
BOLT ISO 7380 M8x10	10 uds

10. MOUNTING THE LIMIT SWITCH AND THE DOOR PRESENCE CONTACT.

10.1. Assembly of the limit switch lever.

The limit switch lever is supplied in two parts to be screwed together.

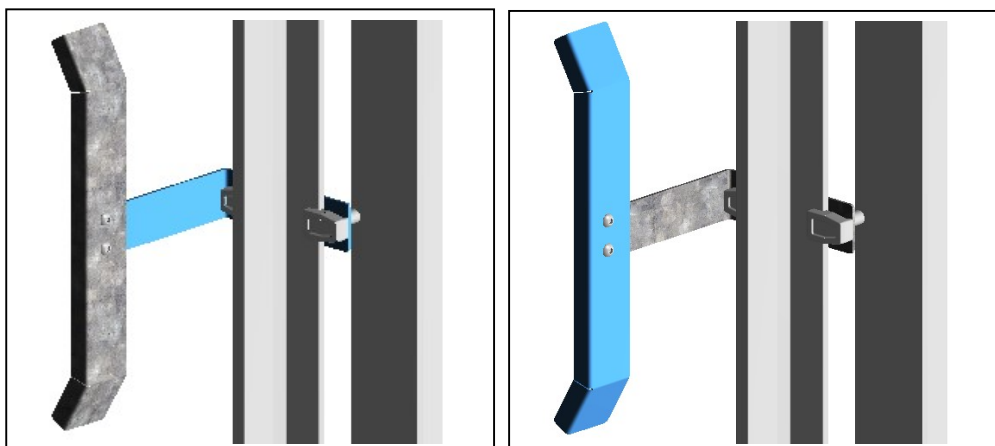
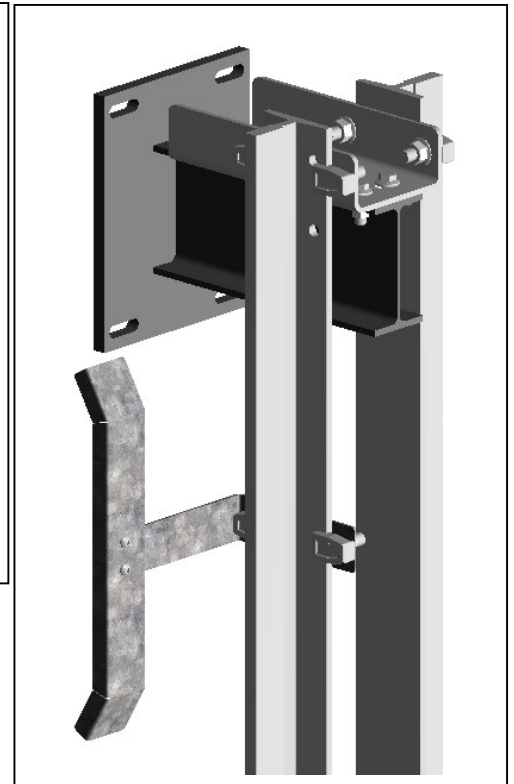
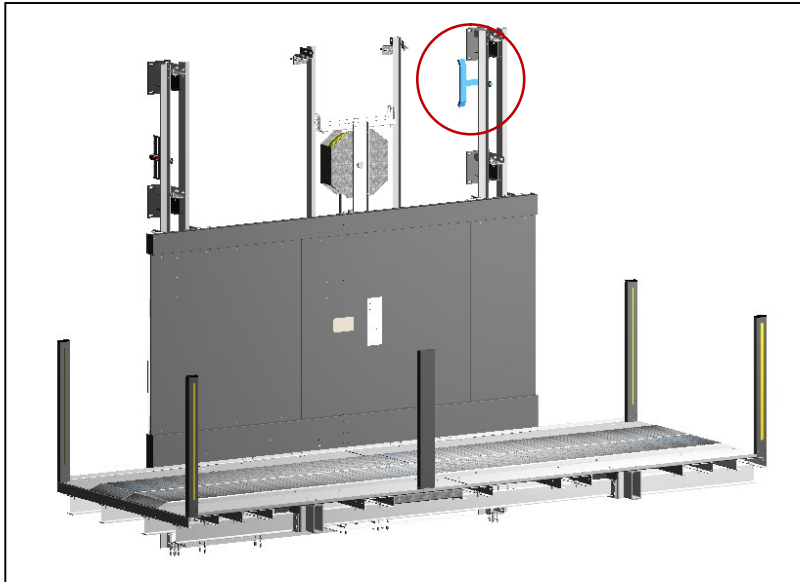

LIMIT SWITCH LEVER

BOLT ISO 7380 M8x20	2 uds
NUT DIN 6923 M8	2 uds
FORGED CLIP M14	2 uds

10.2. Installation of the door zone Contact.

It is necessary to mount as the door zone contacts as there are doors in the opening. The oblongs in the support plate allow the contact to be placed in the most optimal position..

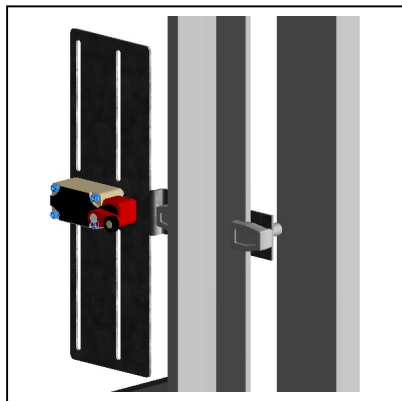
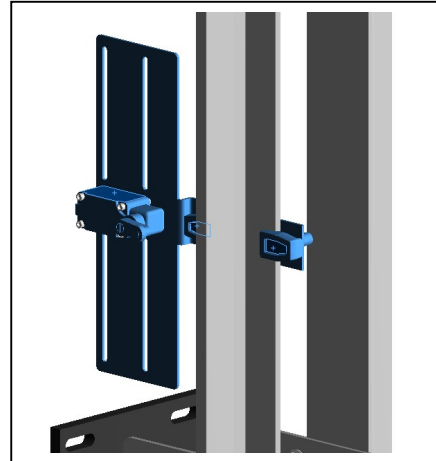
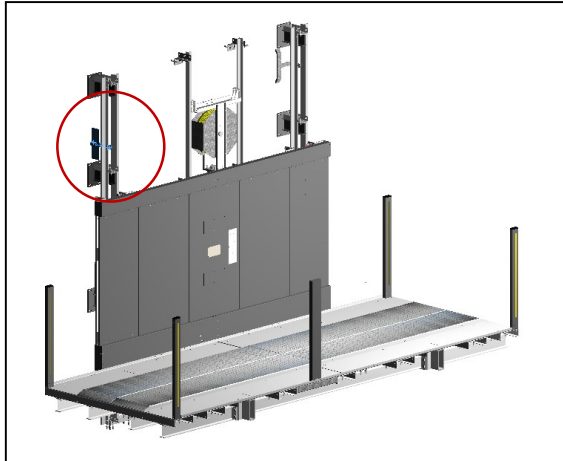

DOOR ZONE CONTACT

BOLT DIN 912 M5x55	4 uds
NUT DIN 6923 M5	4 uds
FORGED CLIP M14	2 uds

10.3. Installation of the door zone levers.

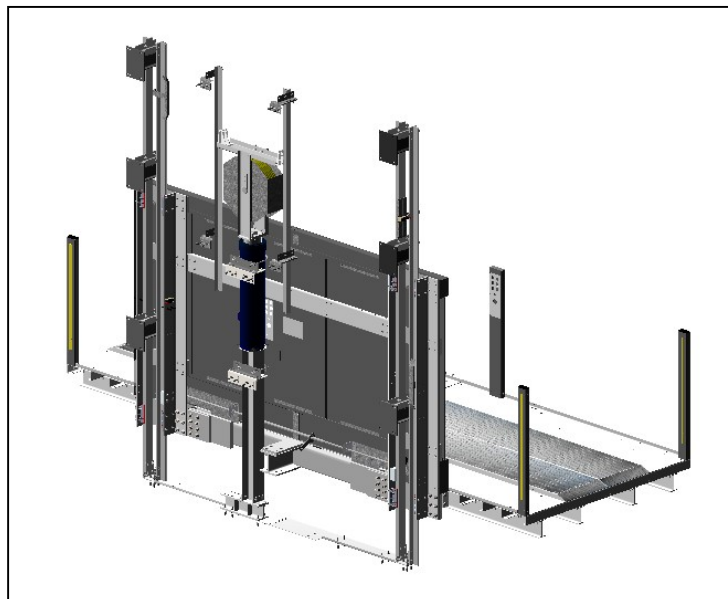

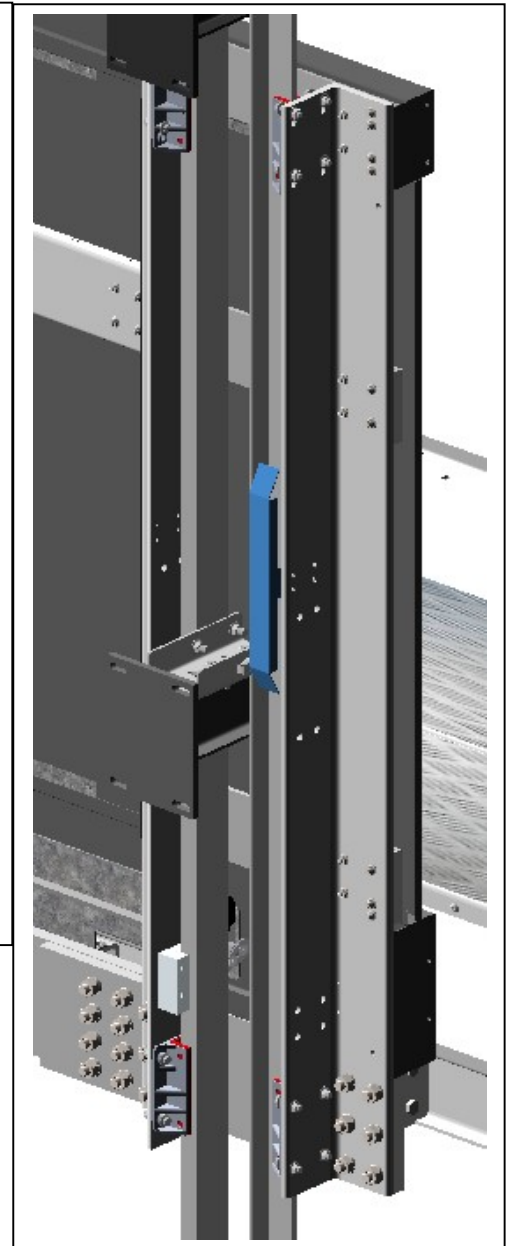

DOOR ZONE LEVERS	
TORNILLO DIN 912 M5x25	4 uds
TUERCA DIN 6923 M5	4 uds

11. SCREWDRIVERS

11.1. BAG N°1 : Screws of mean bedplate to the frame

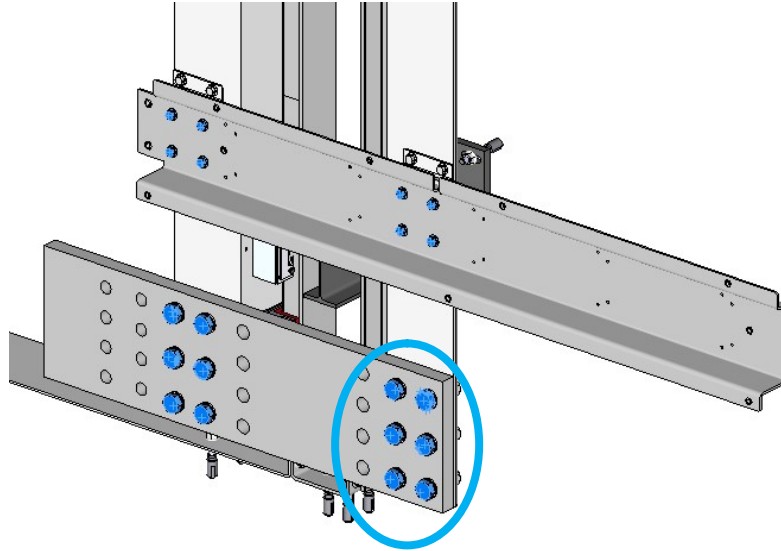

QTY : 24 Pcs M20x80 (DIN 6914)

11.2. BAG N°2 : Screws of mean bedplate to the ropes beam

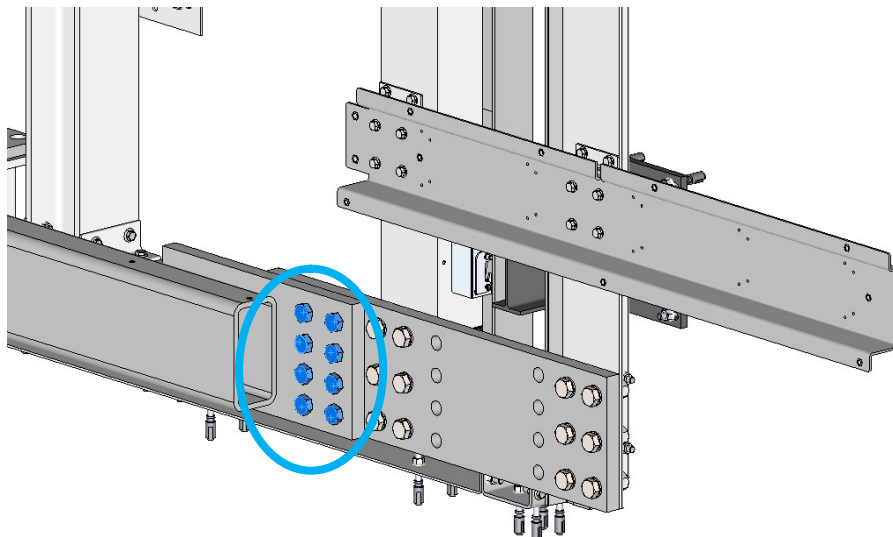

QTY : 16 pcs M20x95 (DIN 6914)

11.3. BAG N°3: Screws of the mean bedplate to the cantilever beams

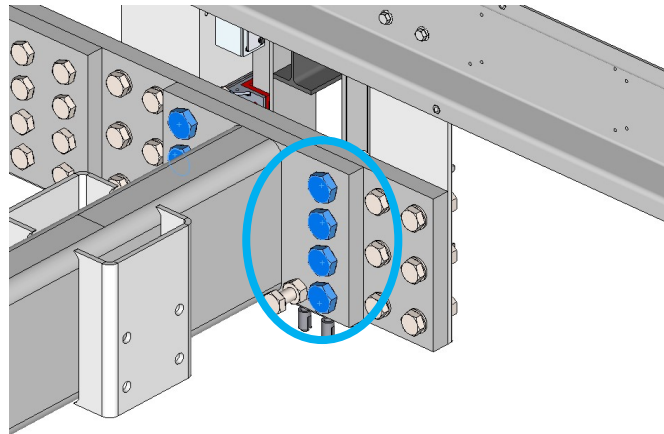

QTY : 16 PCS M24x95 (DIN 6914)

11.4. BAG N°4: Screws os auxiliary beams

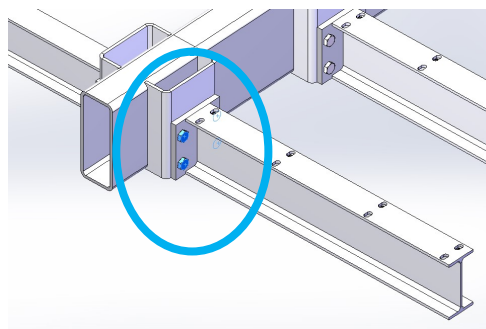
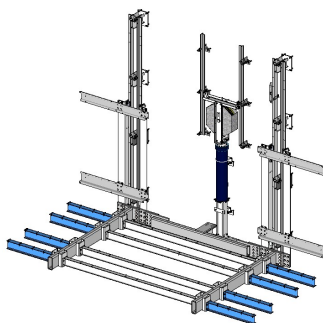
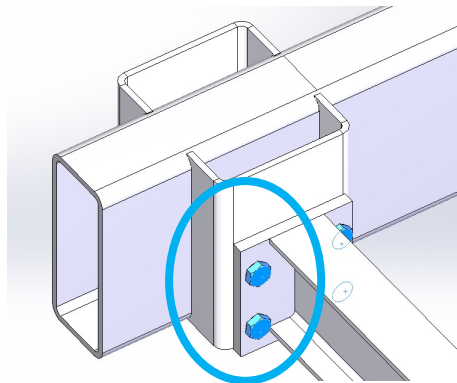
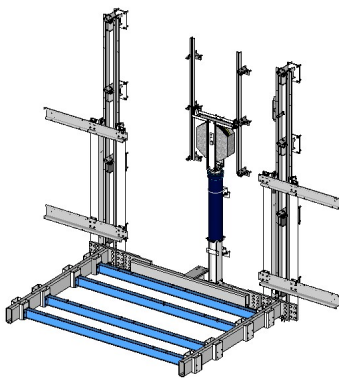

QTY : 64 Pcs M16x50 (DIN 691)

11.5. BAG N°6 : Screws of the bed profiles

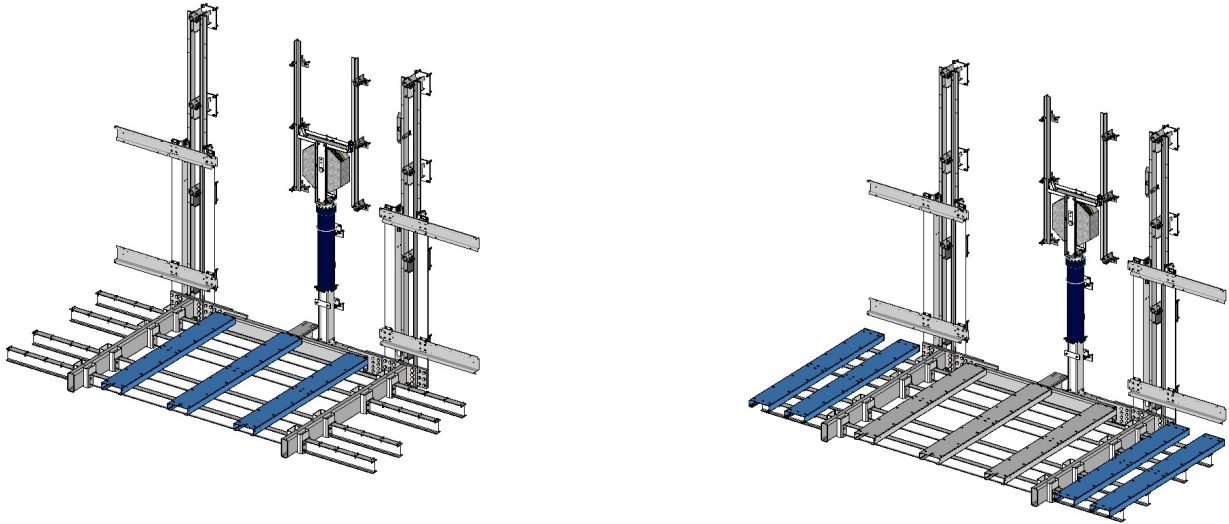

QTY : 112 pcs M12x40 (DIN 933)

11.6. BAG N°6 : Screws of cabin floor

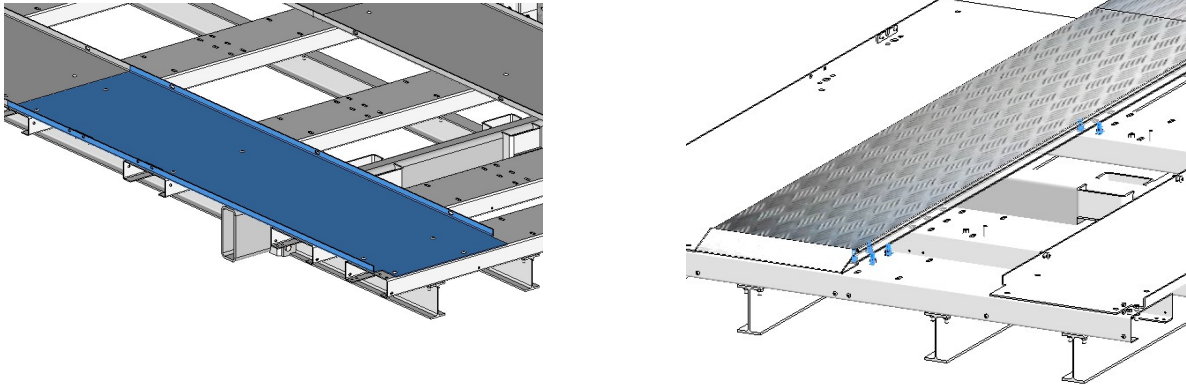

QTY : 70 pcs M12x40 (DIN 7380)



OFICINA CENTRAL

Morispain, S.A.
Polígono Industrial de Jundiz
C/ Arangutxi nº8
01015 Vitoria-Gasteiz
ESPAÑA

+34 945292260
oficinatecnica@morispain.com

www.morispain.com